

OPERATOR'S MANUAL

MODEL 610B

COR-A-TROL

HIGH VOLTAGE SUPPLY/AMPLIFIER/CONTROLLER

TABLE OF CONTENTS

Paragraph	Title	Page
-----------	-------	------

I INSTALLATION

1	NOTICE TO USERS	I-1
1.1	UNPACKING	I-1
1.2	POWER REQUIREMENTS	I-2
1.3	INCOMING INSPECTION	I-2
1.3.1	Tools and Equipment Required	I-3
1.3.2	Functional Check	I-3
1.4	MOUNTING	I-9

II OPERATION

2	SET-UP	II-1
2.1	CONTROLS	II-1
2.1.1	Front Panel	II-2
2.1.1.1	POWER and HV Switches Section.....	II-3
2.1.1.2	FUNCTION Section.....	II-4
2.1.1.2.1	SUPPLY.....	II-4
2.1.1.2.2	AMPLIFIER.....	II-5
2.1.1.2.3	CONTROLLER.....	II-5
2.1.1.3	COMPLIANCE Section.....	II-6
2.1.1.3.1	COMPLIANCE Potentiometer	II-7
2.1.1.3.2	Current Limit Selector Switch	II-7
2.1.1.4	COMMAND/OFFSET Section	II-8
2.1.1.4.1	COMMAND/OFFSET Potentiometer	II-8
2.1.1.4.2	V/I Selector Switch	II-9
2.1.1.4.3	I_t/I_r Selector Switch.....	II-10
2.1.1.4.4	μ A/KV Range Selector Switch	II-11
2.1.1.4.5	Polarity Selector Switch	II-12

TABLE OF CONTENTS (Con't)

Paragraph	Title	Page
II OPERATIONS (Con't)		
2.1.1.5	METER Section	II-13
2.1.2	Rear Panel	II-14
2.1.2.1	AC Power Cord Receptacle and Fuse Box	II-15
2.1.2.2	Remote Control Receptacle	II-15
2.1.2.3	AMP INPUT Receptacle	II-16
2.1.2.4	OUTPUT Section	II-17
2.1.2.4.1	V_O MONITOR OUTPUT Connector	II-17
2.1.2.4.2	I_O MONITOR OUTPUT Connector	II-18
2.1.2.4.3	I_t/I_r Monitor Selector Switch	II-18
2.1.2.5	HV OUT Connector	II-19
2.1.2.6	Ground Connector	II-19
2.1.2.7	I_r Connector	II-20
2.1.2.8	I_s Connector	II-20
2.2	ROUTINE OPERATION	II-21
2.2.1	Supply Mode	II-21
2.2.1.1	Voltage Supply With Adjustable Current Limit	II-21
2.2.1.2	Current Supply With Adjustable Voltage Limit	II-27
2.2.1.2.1	Current Supply I_r Regulated	II-27
2.2.1.2.2	Current Supply I_t Regulated	II-33
2.2.2	Amplifier Mode	II-38
2.2.2.1	Voltage Amplifier	II-39
2.2.2.2	Transconductance Amplifier	II-45
2.2.2.2.1	I_r Output	II-45
2.2.2.2.2	I_t Output	II-51
2.2.3	Controller Mode	II-56
2.2.3.1	Controller Element Modified	II-57
2.3	HOUSEKEEPING	II-65
2.3.1	Clean Case	II-65
2.3.2	Parts Replacement	II-66

TABLE OF CONTENTS (Cont'd)

Paragraph	Title	Page
-----------	-------	------

III THEORY OF OPERATION

3	DESCRIPTION.....	III-1
3.1	THEORY OF OPERATION.....	III-3
3.1.1	Supply	III-3
3.1.2	Amplifier.....	III-3
3.1.3	Controller.....	III-3

IV SPECIFICATIONS

4	SPECIFICATIONS.....	IV-1
4.1	GENERAL INFORMATION.....	IV-1
4.2	VOLTAGE SUPPLY.....	IV-3
4.3	CURRENT SUPPLY.....	IV-4
4.4	AMPLIFIER AND CONTROLLER.....	IV-5
4.5	COMPLIANCE CONTROL.....	II-6

Figure	Title	Page
--------	-------	------

ILLUSTRATIONS

1	Plug Cord Into Power Source.....	I-4
2	FUNCTION Switch in SUPPLY Position.....	I-4
3	Set Controls in COMMAND/OFFSET Section.....	I-5
4	Turn Dial to 10.....	I-6
5	Set Controls in METER Section.....	I-6
6	POWER Switch in ON Position.....	I-7
7	HV Switch in ON Position.....	I-7
8	Polarity Switch in “+” Position.....	I-8
9	Turn Dial CW.....	I-8
10	Polarity Switch to “-” Position.....	I-9
11	Front Panel.....	II-2
12	POWER and HV Switches.....	II-3
13	Switch in SUPPLY Position.....	II-4

TABLE OF CONTENTS (Cont'd)

Figure	Title	Page
--------	-------	------

ILLUSTRATIONS (Cont'd)

14	Switch in AMPLIFIER Position	II-5
15	Switch in CONTROLLER Position	II-6
16	Amber LED	II-6
17	COMPLIANCE Potentiometer	II-7
18	Current Limit Selector Switch	II-7
19	COMMAND/OFFSET Potentiometer	II-9
20	V/I Selector Switch	II-9
21	I_t/I_r Selector Switch	II-10
22	$\mu\text{A}/\text{KV}$ Range Selector Switch	II-12
23	Polarity Selector Switch	II-13
24	METER Section Controls	II-13
25	Rear Panel Controls	II-14
26	AC Power Cord Receptacle and Fuse Box	II-15
27	Remote Control Receptacle	II-15
28	AMP INPUT Receptacle	II-16
29	Pin Connections	II-16
30	V_O MONITOR OUTPUT Connector	II-17
31	I_O MONITOR OUTPUT Connector	II-18
32	I_t/I_r Monitor Selector Switch	II-18
33	HV OUT Connector	II-19
34	Ground Connector	II-19
35	I_r Connector	II-20
36	I_s Connector	II-20
37	POWER and HV Switches Set to OFF	II-21
38	Example of Rear Panel Connections	II-22
39	Plug Power Cord Into 610B Receptacle	II-23
40	Plug Power Cord Into Power Source	II-23
41	Example of Front Panel Settings	II-24
42	POWER Switch to ON	II-25
43	HV Switch to ON	II-25
44	POWER and HV Switches to OFF	II-27
45	Sample Rear Panel Hook-up I_r Regulated	II-28
46	Plug Power Cord Into 610B Receptacle	II-29
47	Plug Power Cord Into Power Source	II-29
48	Example of Front Panel Settings	II-30
49	POWER Switch to ON	II-32
50	HV Switch to ON	II-32
51	POWER and HV Switches to OFF	II-33
52	Sample Rear Panel Hook-up I_r Regulated	II-34
53	Plug Power Cord Into 610B Receptacle	II-35

TABLE OF CONTENTS (Cont'd)

Figure	Title	Page
--------	-------	------

ILLUSTRATIONS (Cont'd)

54	Plug Power Cord Into Power Source	II-35
55	Example of Front Panel Settings	II-36
56	POWER Switch to ON	II-37
57	HV Switch to ON	II-37
58	Pin Connections for Input Variations	II-38
59	POWER and HV Switches to OFF	II-39
60	Example of Rear Panel Connections	II-40
61	Plug Power Cord Into 610B Receptacle	II-41
62	Plug Power Cord Into Power Source	II-41
63	Example of Front Panel Settings	II-42
64	POWER Switch to ON	II-43
65	HV Switch to ON	II-43
66	POWER and HV Switches to OFF	II-45
67	Example of Rear Panel Connections	II-46
68	Plug Power Cord into 610B Receptacle	II-47
69	Plug Power Cord into Power Source	II-47
70	Example of Front Panel Settings	II-48
71	POWER Switch to On	II-49
72	HV Switch to ON	II-49
73	POWER and HV Switches to OFF	II-51
74	Example of Rear Panel Connections	II-51
75	Plug Power Cord into 610B Receptacle	II-52
76	Plug Power Cord into Power Source	II-52
77	Example of Front Panel Settings	II-53
78	POWER Switch to ON	II-54
79	HV Switch to ON	II-54
80	610B as Controller in Closed-loop System	II-56
81	POWER and HV Switches OFF	II-57
82	Disconnect Cord from Power Source	II-57
83	Remove 610B Cover	II-58
84	Remove R14 Resistor	II-59
85	Replace Cover and Screws	II-60
86	Example of Rear Panel Connections	II-60
87	Plug Power Cord Into 610B Receptacle	II-61
88	Plug Power Cord Into Power Source	II-61
89	Example of Front Panel Settings	II-62
90	POWER Switch to ON	II-63
91	HV Switch to On	II-63
92	Cleaning the Case	II-65
93	Parts Replacement	II-66
94	610B Unit	III-2

TABLE OF CONTENTS (Cont'd)

Letter	Title	Page
--------	-------	------

APPENDICES

A	Glossary of Terms.....	A-1
---	------------------------	-----

SECTION 1 INSTALLATION

1 NOTICE TO USERS

Warnings and Cautions are interspersed with instructions in this manual to make you aware of the hazards you may encounter. Warnings are used to advise you of an action or actions which may cause harm to you, the operator. Cautions are used to advise you of an action or actions which may cause harm to the equipment.

1.1 UNPACKING

Upon receipt of the package from the shipper, visually inspect the shipping container for any dents or other damage. Note any such irregularities and have the shipper verify the damage. Report the damage to the appropriate insurance authority immediately.

If no external damage has been found, then remove the instrument from the packing. Visually inspect the casing for physical damage, i.e., dents, nicks, scratches, broken fittings, loose wires, etc. In the event of damage, notify the factory or your nearest Trek representative. Attempts to use a damaged instrument may cause permanent damage to the unit.

1.2 POWER REQUIREMENTS

The 610B is equipped with a standard 3-prong plug providing a grounded chassis when the cord is used in a grounded power receptacle.

WARNING

Make no attempt to bypass the ground prong in the power cable. This is a safety feature and any attempt to negate it can result in a painful shock to the user and/or damage to the equipment.

Ensure that the power supply available in your area corresponds to the voltage requirements indicated on the label at the back of the 610B. The 610B operates from a standard 110 VAC, 50 to 60 Hz power supply without alterations.

1.3 INCOMING INSPECTION

The 610B undergoes extensive checks and adjustments at the factory and should require no initial calibration. As part of the incoming inspection on equipment you may wish to perform a functional check.

1.3.1 Tools and Equipment Required

No special tools or equipment are required to perform the functional check on the 610B.

1.3.2 Functional Check

Prior to starting the functional check, read the description on the 610B controls. This procedure is designed to verify only the basic operation of the instrument. To perform the functional check:

WARNING

This equipment generates high voltages. Read all instructions and warnings before proceeding. Use caution when operating the equipment.

CAUTION

Make no attempt to bypass the ground feature in the power cable. This is a safety feature and any attempt to negate it can result in a painful shock to the user and/or damage to the equipment.

- a. Plug the 610B power cord into a standard power source (see Figure 1). Do not plug in the high-voltage cable.

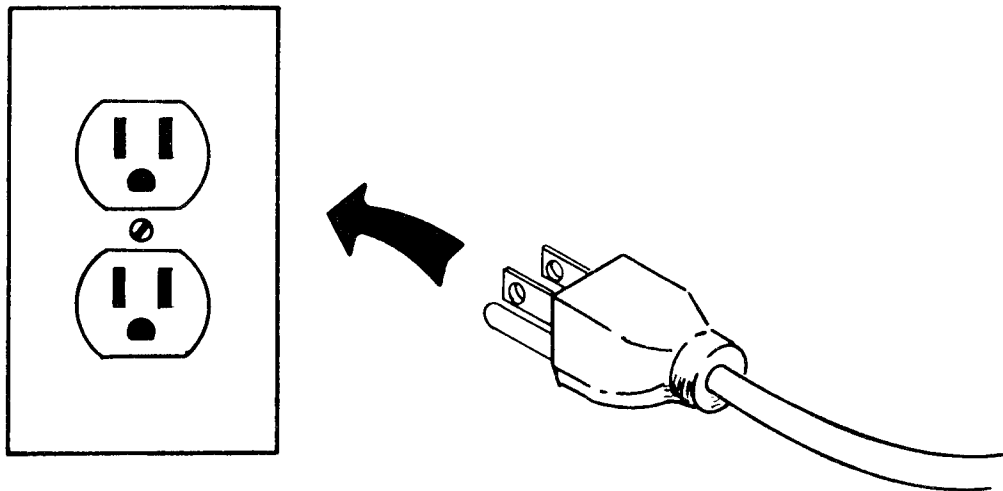

Figure 1. Plug Cord into Power Source

- b. Set the FUNCTION switch to SUPPLY (see Figure 2).

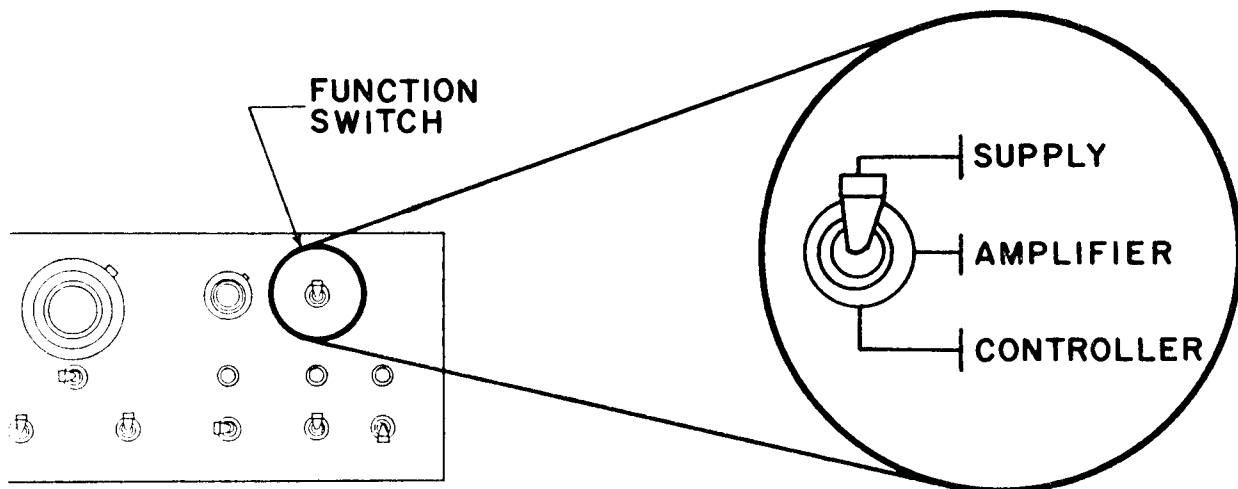

Figure 2. FUNCTION Switch in SUPPLY Position

c. In the COMMAND/OFFSET Section:

- (1) Set the selector switch to the "V" position (see Figure 3).
- (2) Set the range selector switch to the "0-10 KV" position (refer to Figure 3).
- (3) Adjust the potentiometer dial to zero by turning the dial fully counterclockwise (CCW). You may need to unlock the dial by pushing up on the lever at the base of the dial (refer to Figure 3).
- (4) Flip the polarity switch to the OFF position (refer to Figure 3).

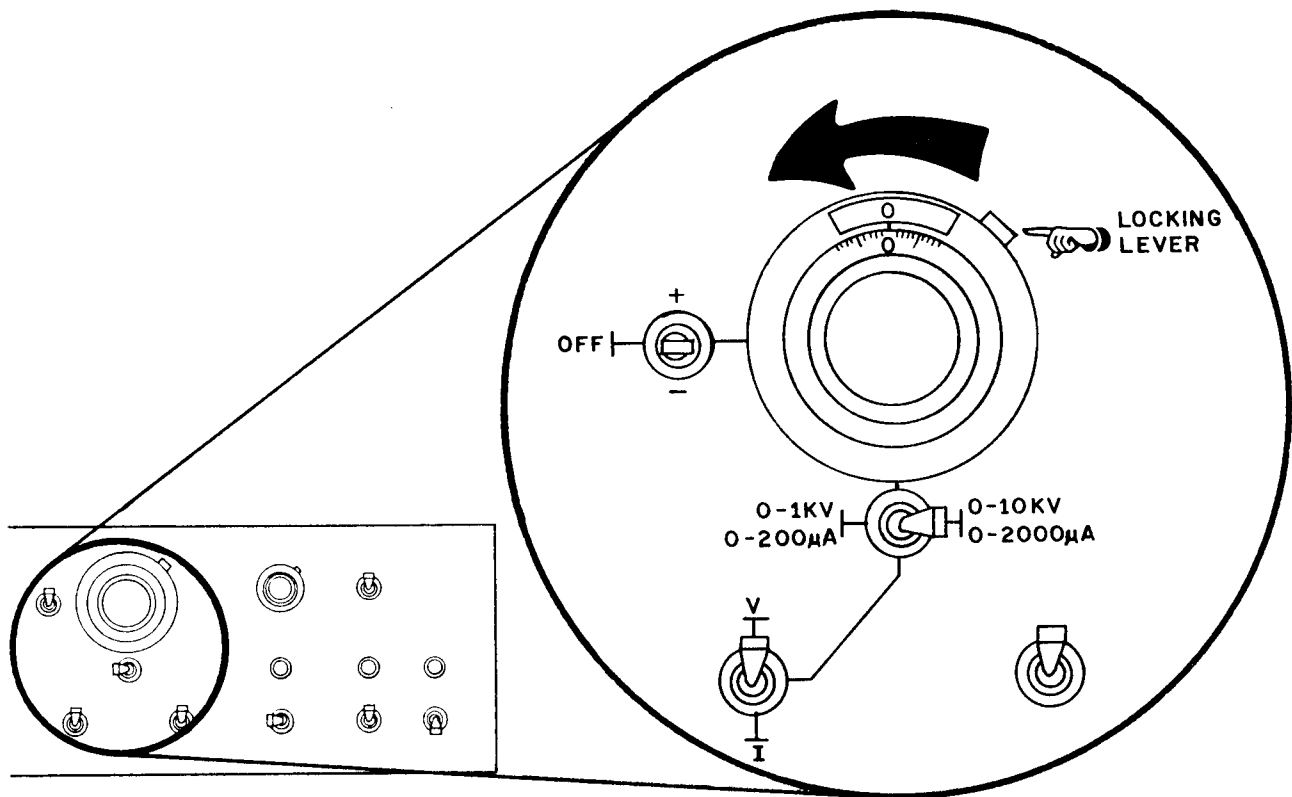

Figure 3. Set Controls in COMMAND/OFFSET Section

- d. Adjust the COMPLIANCE LEVEL potentiometer dial to "10" by turning the dial fully clockwise (CW). You may need to unlock the control by pushing up on the lever at the base of the dial to make this adjustment. Reset the lock when the dial is set (see Figure 4).

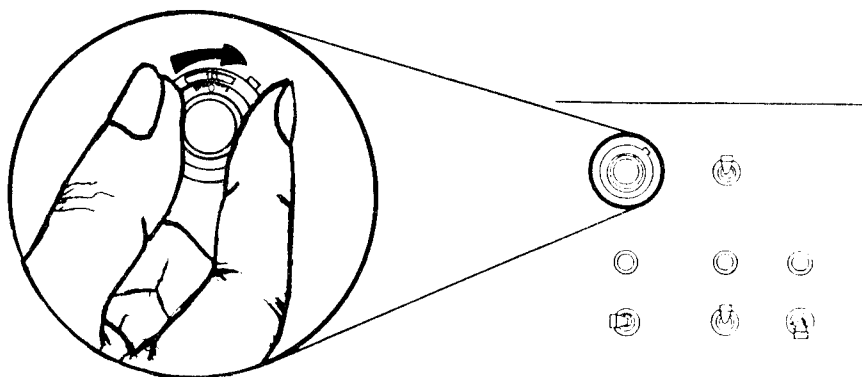

Figure 4. Turn Dial to 10

- e. In the METER Section (see Figure 5):
- (1) Flip the selector switch to the "V" position.
 - (2) Flip the range switch to the "0-10 KV" position.

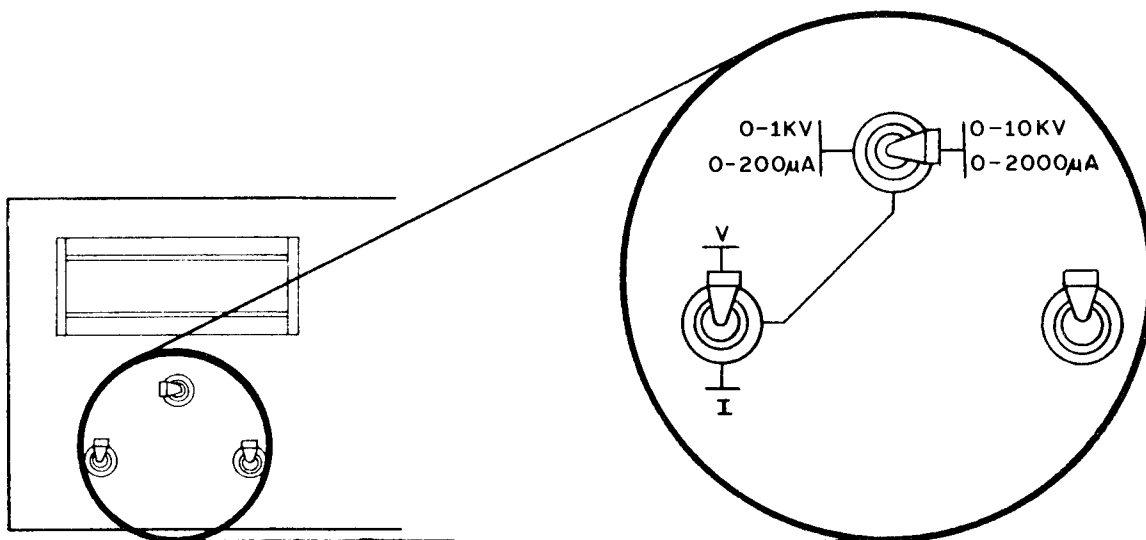

Figure 5. Set Controls in METER Section

f. Flip the 610B POWER switch to the ON position (see Figure 6).

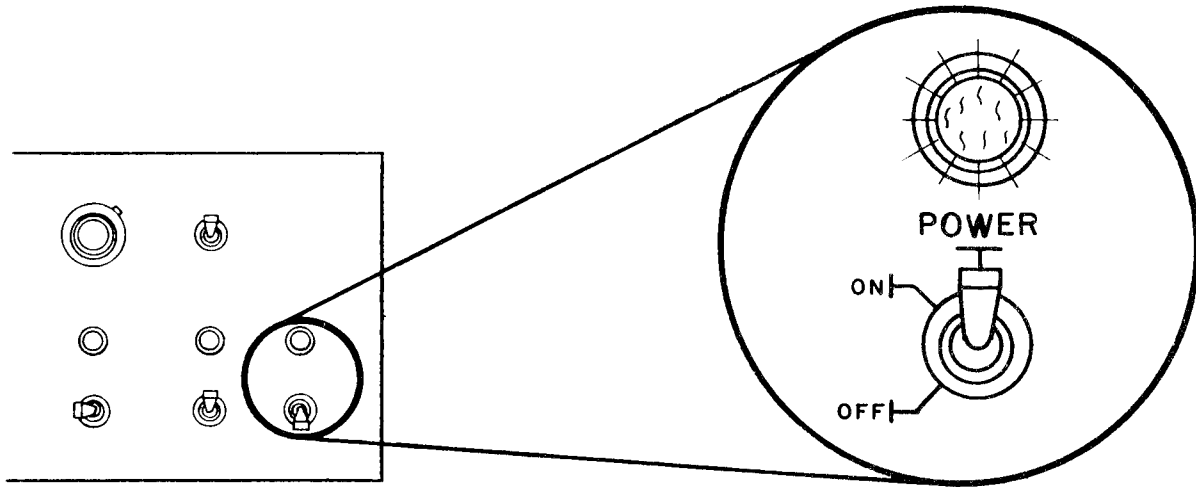

Figure 6. POWER Switch in ON Position

g. Wait thirty seconds and then flip the HV switch to the ON position (see Figure 7).

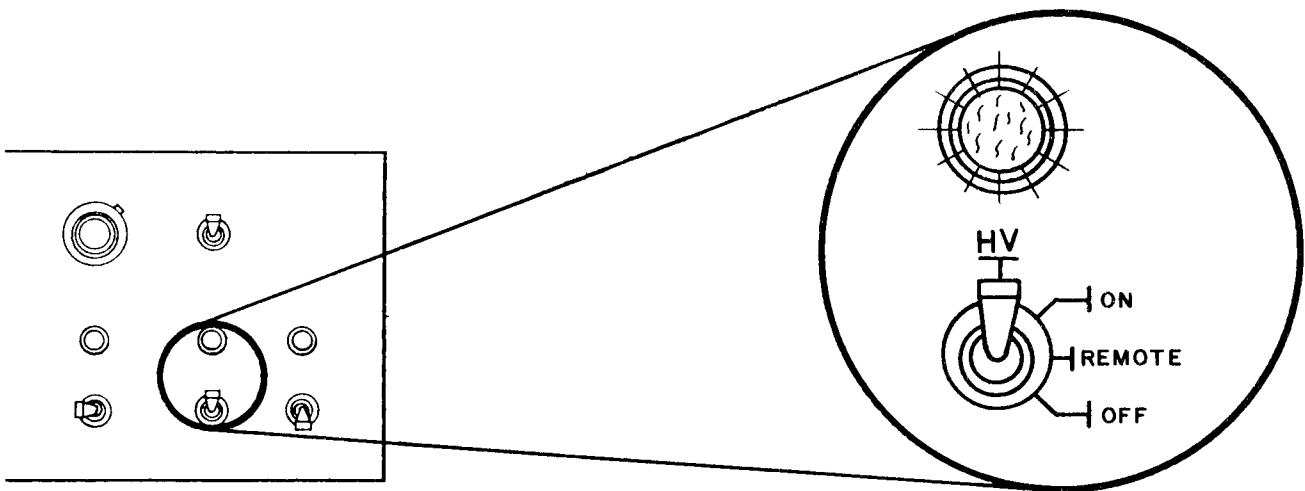

Figure 7. HV Switch in ON Position

h. Flip the polarity switch to the “+” position (see Figure 8).

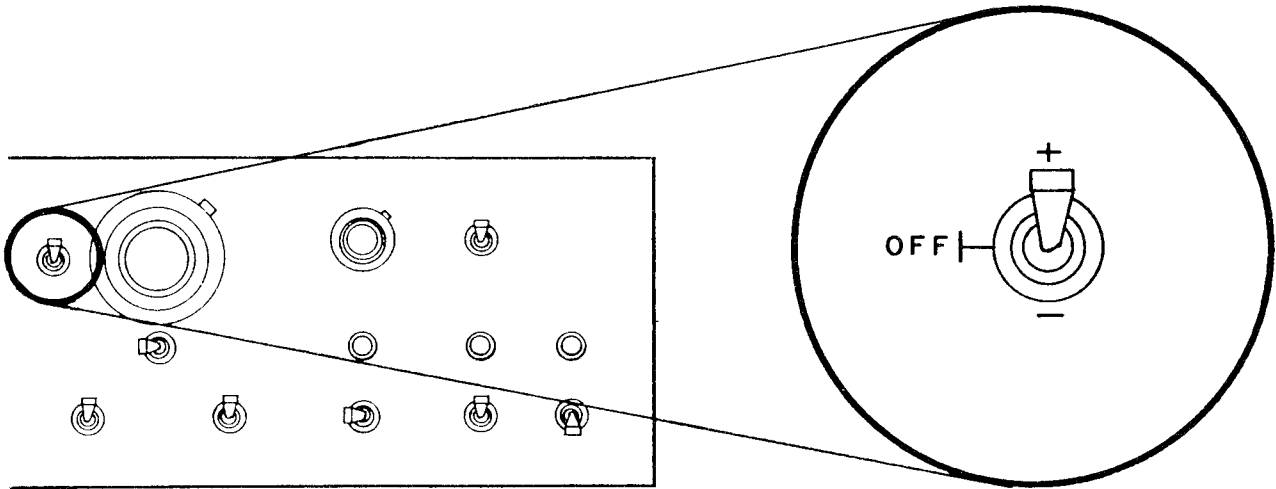

Figure 8. Polarity Switch in “+” Position

i. Turn the COMMAND/OFFSET dial fully CW. You may need to unlock the dial to make this adjustment. Reset the lock when the dial is set. The DPM begins reading. When the dial is completely CW, the DPM reads +10.00 (see Figure 9).

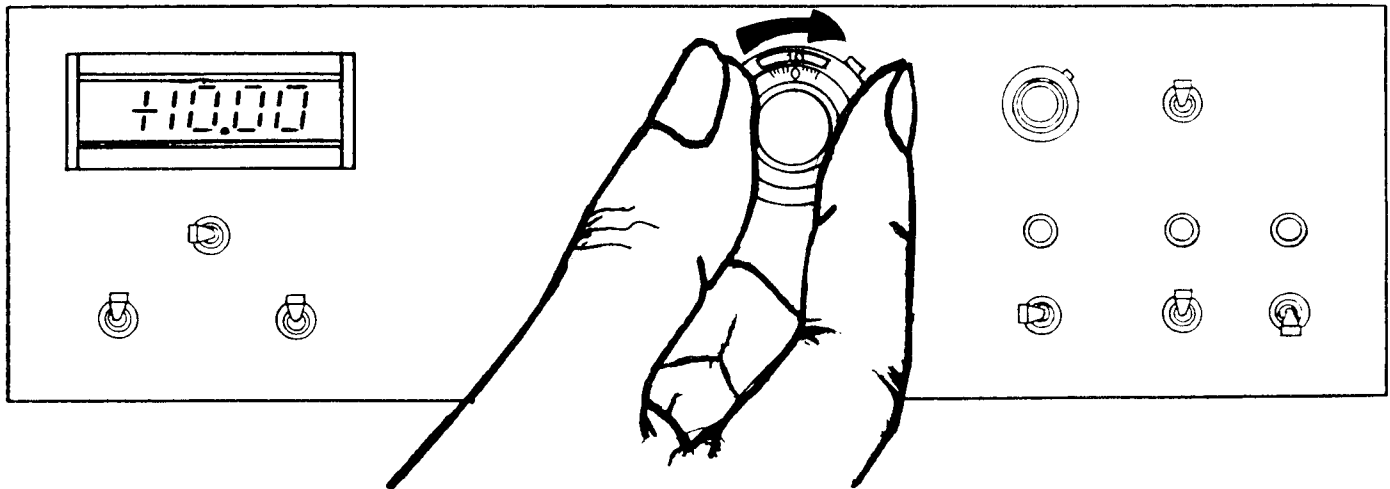

Figure 9. Turn Dial CW

- j. Flip the polarity switch to the “-” position (see Figure 10). The DPM should read -10.0.

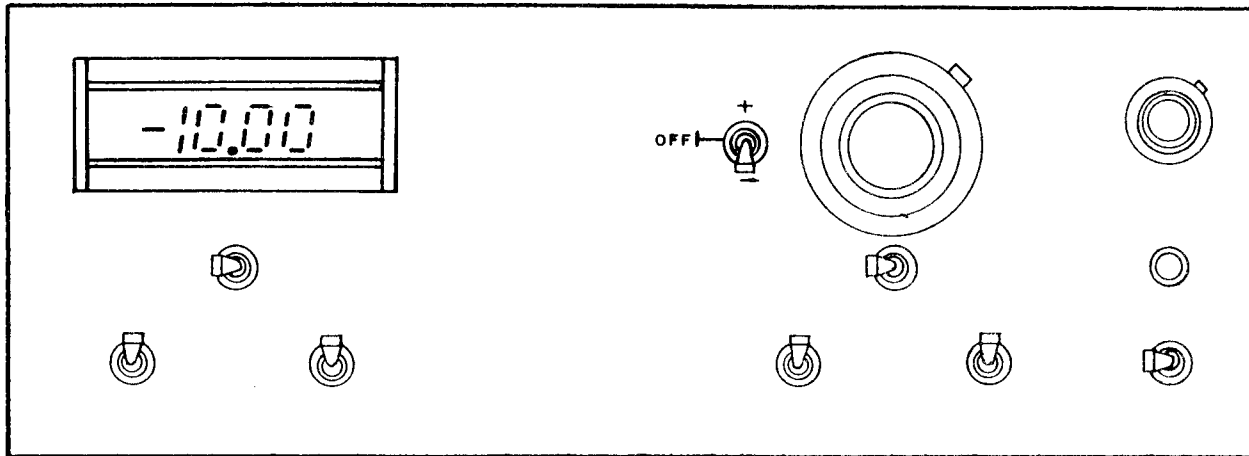

Figure 10. Polarity Switch to “-” Position

- k. The test is now complete. Flip the POWER switch to the OFF position.

1.4 MOUNTING

The 610B base unit may be rack installed or it can be used as a tabletop unit.

Trek offers a rack-mounting option. With the rack mount options the 610B can be mounted in a standard 19-inch rack. Installation instructions are included with the rack-mounting hardware assembly.

SECTION II OPERATION

2 SET UP

The 610B is ready for use upon arrival. You may control it as a local unit or operate it in a remote mode. Use only a grounded power source. You may use it as a tabletop unit or, with a Trek conversion kit, you may use it rackmounted.

2.1 CONTROLS

The controls on the 610B are fully visible and easy to operate. The receptacles are clearly labeled.

WARNING

This equipment generates high voltage. Read all instructions and warnings before proceeding. Use caution when operating the equipment.

2.1.1 Front Panel

The front panel is functionally divided into five sections (see Figure 11).

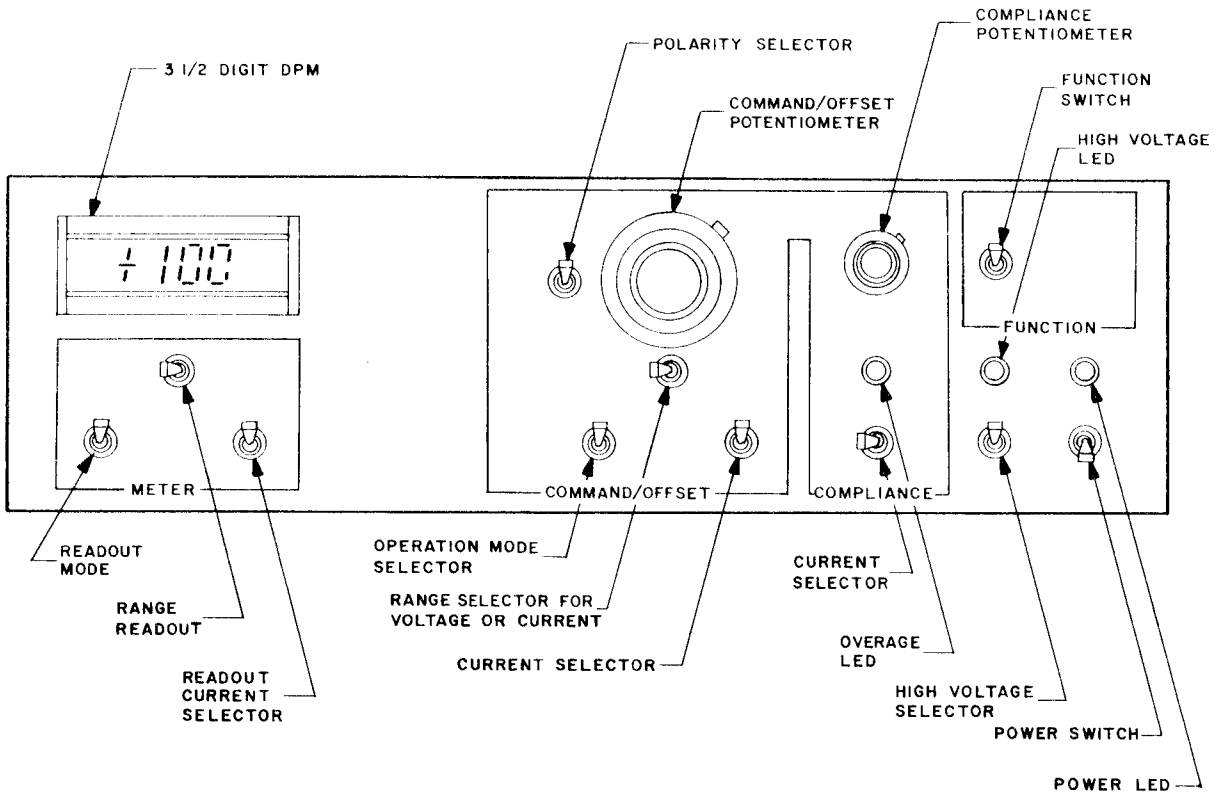

Figure 11. Front Panel

2.1.1.1 POWER and HV Switches Section

The POWER switch is a two-position switch, ON and OFF. When the POWER switch is in the ON position, the green LED above it is illuminated indicating that power is applied to the control circuits and the output regulator heater circuit (see Figure 12).

The HV control is a three-position switch (refer to Figure 12). In the ON position it activates the high-voltage power supplies. The red LED illuminates when the switch is set to ON or when the unit is in the REMOTE mode and pins 3 and 6 of the EXT. CONTROL connector are shorted, indicating that high-voltage may be present at the HV OUT connector.

NOTE

Wait thirty seconds after activating the POWER switch before activating the HV switch.

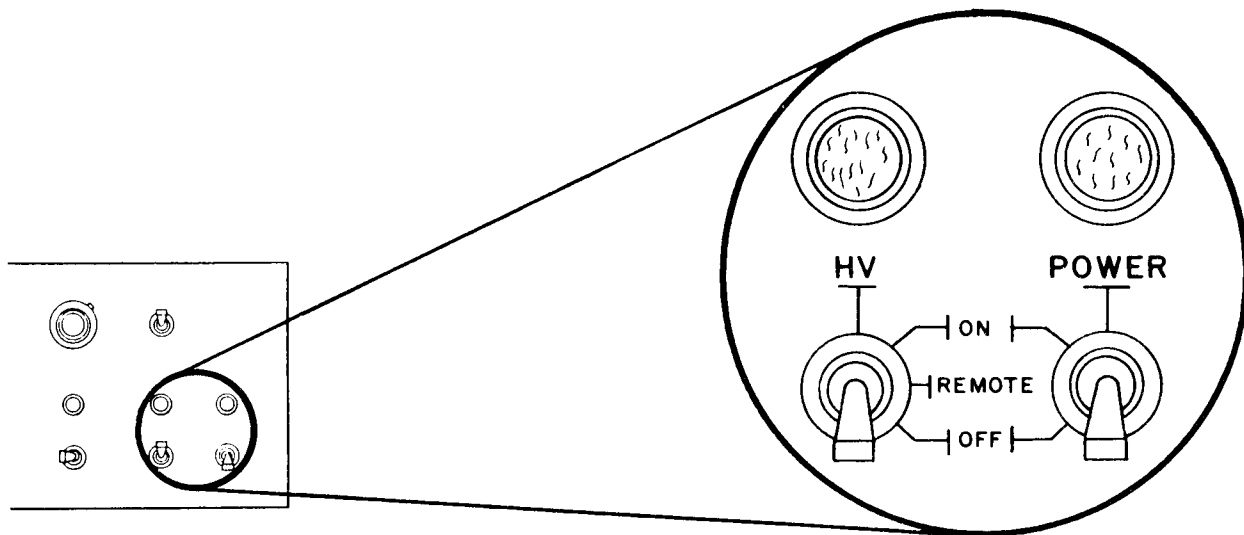

Figure 12. POWER and HV Switches

2.1.1.2 FUNCTION Section

There are three function controls: SUPPLY, AMPLIFIER, and CONTROLLER.

2.1.1.2.1 SUPPLY

In the SUPPLY position, the 610B functions as a precise, adjustable, high-voltage power supply with an adjustable current limit; or as a precise, adjustable current supply with an adjustable voltage limit (see Figure 13).

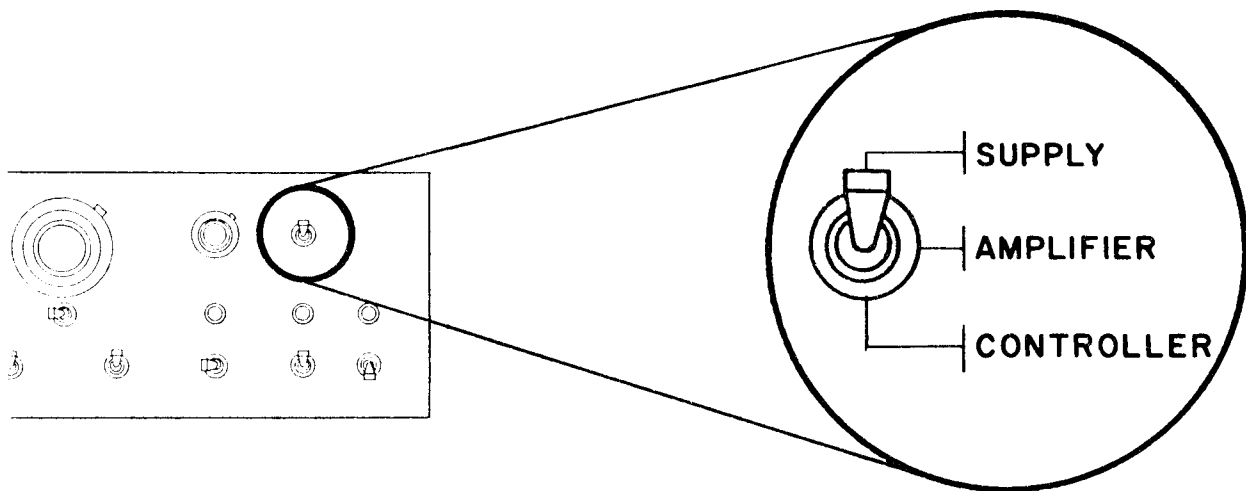

Figure 13. Switch in SUPPLY Position

2.1.1.2.2 **AMPLIFIER**

In the AMPLIFIER mode, output voltage or output current are proportional to a voltage input signal control applied to the 610B through a rear panel mounted connector (see Figure 14).

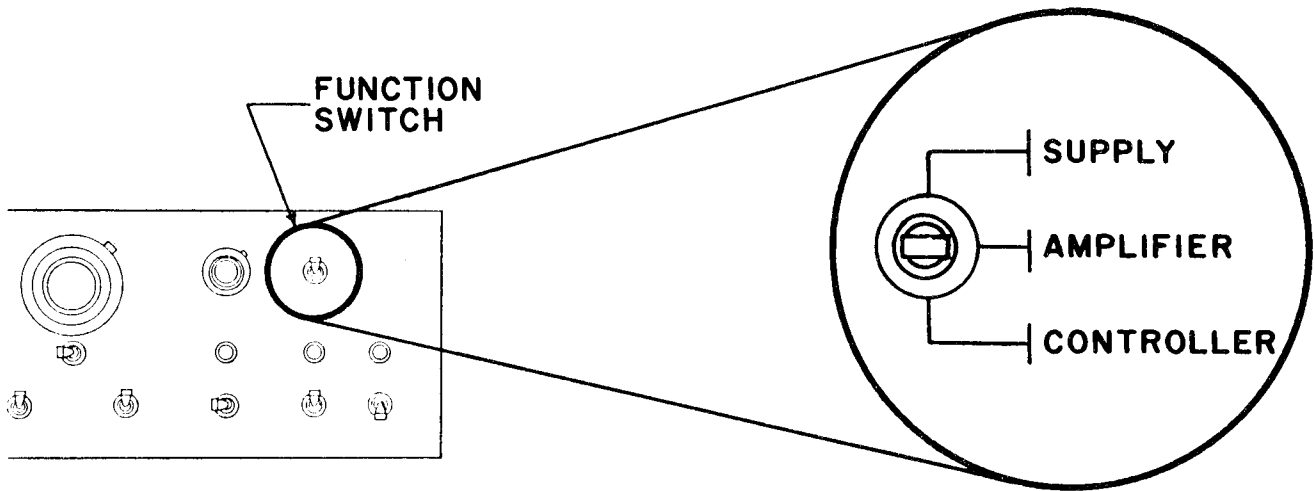

Figure 14. Switch in AMPLIFIER Position

2.1.1.2.3 **CONTROLLER**

In the CONTROLLER mode, the input configuration is maintained as in the amplifier mode, while the amplifier's input and feedback parameters are left uncommitted and available for user selection (refer to Figure 15).

Terminals for the installation of resistor and/or capacitor elements provide the means for tailoring the 610B gain characteristics to your particular requirements.

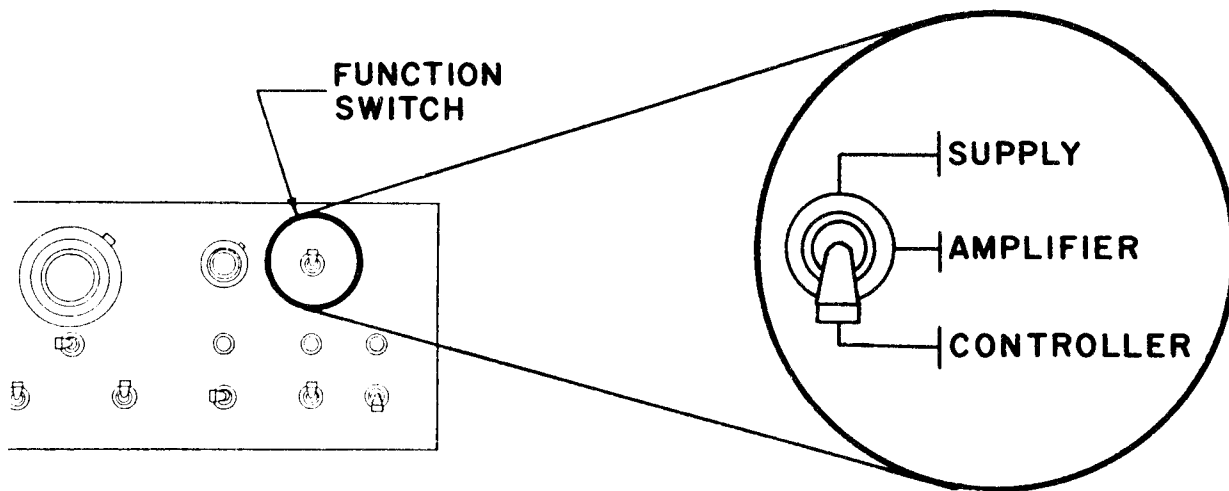

Figure 15. Switch in CONTROLLER Position

2.1.1.3 COMPLIANCE Section

There are only two controls in this section: a ten-turn potentiometer and a selector switch. An amber LED illuminates to indicate an operation in the compliance limit range: overvoltage in the current mode; overcurrent in the voltage mode.

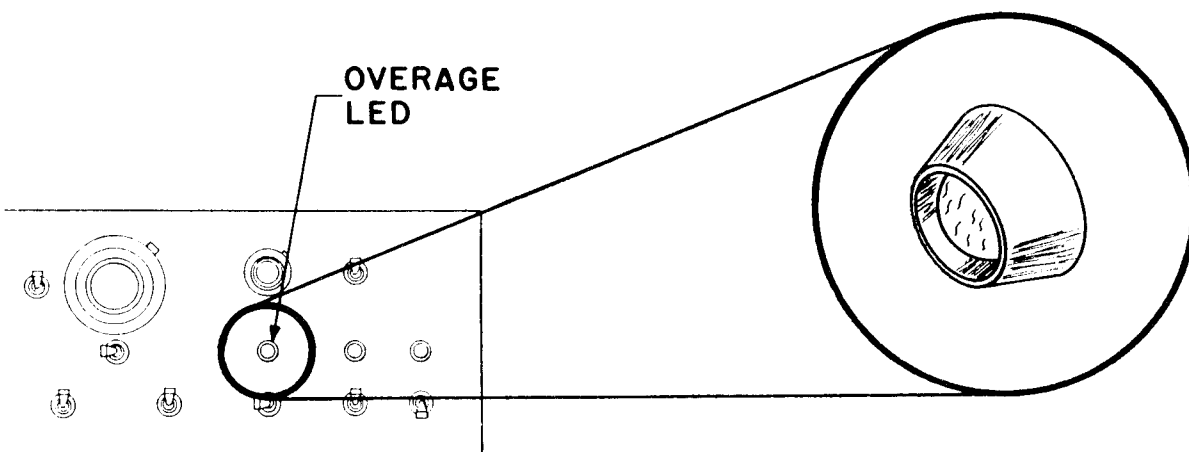

Figure 16. Amber LED

2.1.1.3.1 COMPLIANCE Potentiometer

The ten-turn COMPLIANCE potentiometer is used to set the limit value of load current (I_t or I_r) when the unit is in a voltage mode of operation or to set the limit value of output voltage when the 610B is in the current mode of operation (see Figure 17). The dial has a lock at its base. To disengage the lock, push upward, turn the dial to the desired position, and then push downward to engage the lock.

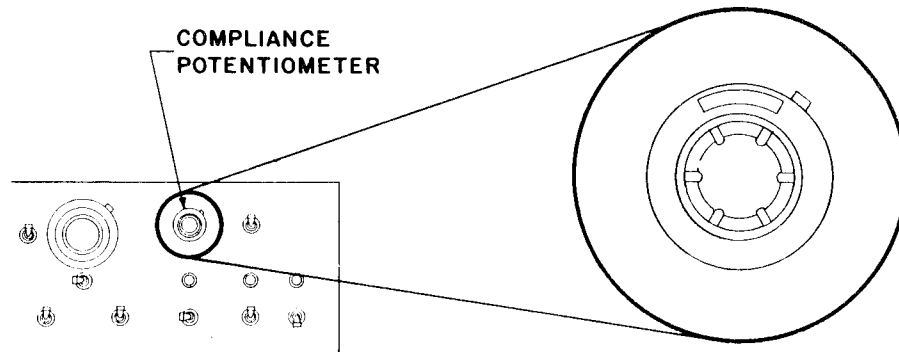

Figure 17. COMPLIANCE Potentiometer

2.1.1.3.2 Current Limit Selector Switch

This switch determines which current, I_t or I_r , is to be limited when the unit is in a voltage mode (see Figure 18). I_r is the current which flows through the rear panel mounted I_r terminal, while I_t is the total current flowing in the HV OUTPUT connector.

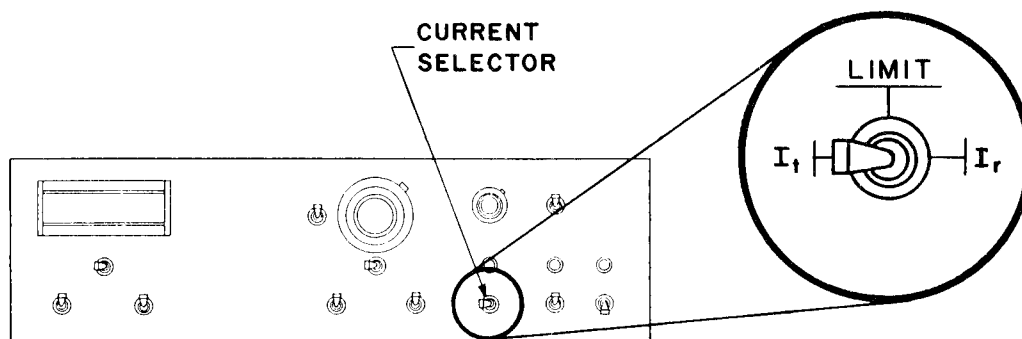

Figure 18. Current Limit Selector Switch

2.1.1.4 **COMMAND/OFFSET Section**

The COMMAND/OFFSET section has four switches and one potentiometer dial.

2.1.1.4.1 **COMMAND/OFFSET Potentiometer**

This ten-turn potentiometer dial is used to (see Figure 19):

- a. Command the load voltage when the unit is used as a voltage supply.
- b. Command the load current, I_t or I_r , when the unit is used as a current supply.
- c. Set the offset voltage when the unit is in the voltage amplifier or voltage controller modes.
- d. Set the offset current, I_t or I_r , when the unit is in the current amplifier or current controller modes.

This dial has a lock at its base. To disengage the lock, push upward, turn the dial to the desired position, and then push downward to engage the lock.

When in the current supply mode or current amplifier mode, the output current is equal to two times the dial setting value.

EXAMPLE:

In the I_t mode:

**with the $\mu\text{A}/\text{KV}$ range switch
set to

0-200 μA

full potentiometer = 200 μA

**with the $\mu\text{A}/\text{KV}$ range switch
set to

0-2000 μA

full potentiometer = 2000 μA

In the voltage mode, any value up to 1 KV can be directly selected by the potentiometer dial with the $\mu\text{A}/\text{KV}$ range switch set to "0-1KV" and any value up to 10 KV can be directly selected by the potentiometer dial with the $\mu\text{A}/\text{KV}$ range switch set to "0-10KV".

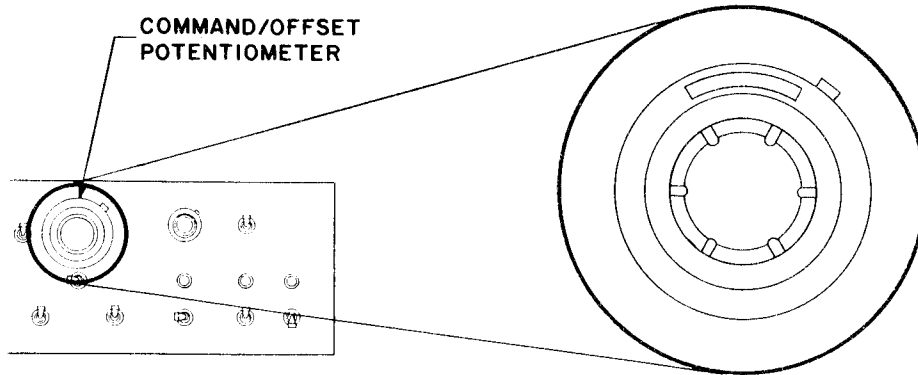

Figure 19. COMMAND/OFFSET Potentiometer

2.1.1.4.2 V/I Selector Switch

Select the operational mode with the “V/I” selector switch (see Figure 20). With the switch in the “V” position, the system is in the voltage mode and the potentiometer dial commands the load voltage when the unit is functioning as a voltage supply or sets the offset load voltage when the 610B functions as a voltage amplifier or voltage controller. With the switch in the “I” position, the potentiometer dial commands the load current, I_t or I_r , when the 610B is functioning as a current supply or sets the load offset current when the unit is functioning in the transconductance amplifier or transconductance controller mode.

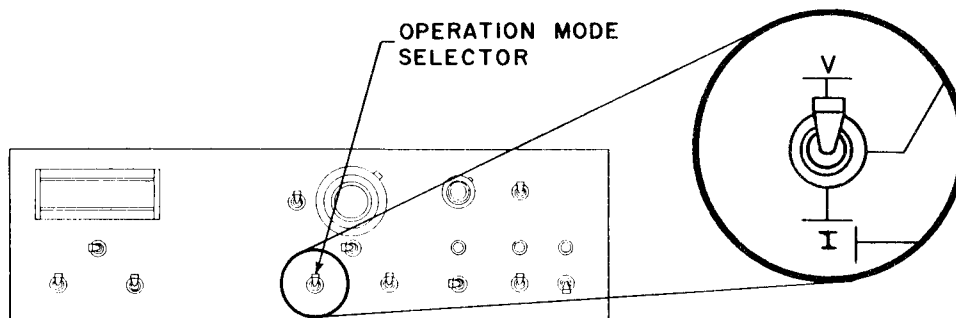

Figure 20. V/I Selector Switch

2.1.1.4.3 I_t/I_r Selector Switch

The position of the I_r/I_t switch is relevant only when the 610B is in a current mode (see Figure 21).

With the switch in the " I_r " position, you can command the load current, I_r , when the 610B is functioning as a current supply, or set the I_r return offset current when the 610B is functioning as a transconductance amplifier or transconductance controller.

With the switch in the " I_t " position, you can command the total load current, I_t , when the 610B is functioning as a current supply, or set the I_t offset current when the 610B is functioning as a transconductance amplifier or transconductance controller.

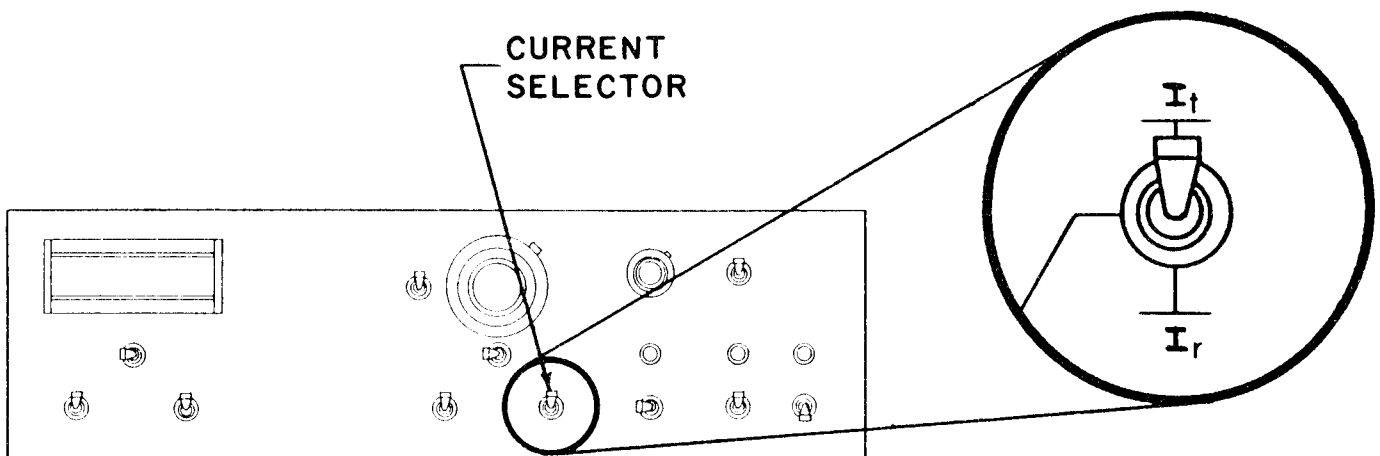

Figure 21. I_r/I_t Selector Switch

2.1.1.4.4

μ A/KV Range Selector Switch

The μ A/KV range selector switch (see Figure 22):

- a. Determines the maximum output voltage at 1 KV or 10 KV when the unit is functioning as a voltage supply.
- b. Selects the full scale load current, I_1 or I_r , at 200 μ A or 2,000 μ A when the 610B is functioning as a current supply.
- c. Selects the amplifier gain and the maximum output offset voltage when the 610B is functioning as a voltage amplifier:
 1. "0 - 1 KV" position equals 100 volts output per volt input.
 2. "0 - 10 KV" position equals 1,000 volts output per volt input.
- d. Determines the transconductance gain and the maximum load offset current, I_1 or I_r , when the unit is functioning as a transconductance amplifier:
 1. "0 - 200 μ A" position equals 20 μ A output per volt input.
 2. "0 - 2000 μ A" position equals 200 μ A output per volt input.
- e. Selects a 10 to 1 voltage scale factor of voltage gain and the maximum output offset voltage when the 610B is functioning in the voltage controller mode. Voltage controller gain and maximum voltage offsets are alterable by your component selection.
- f. Selects a 10 to 1 scale factor of current gain and maximum output offset current when the 610B is operating in the transconductance controller mode. Controller transconductance and load offset currents are alterable by your component selection.

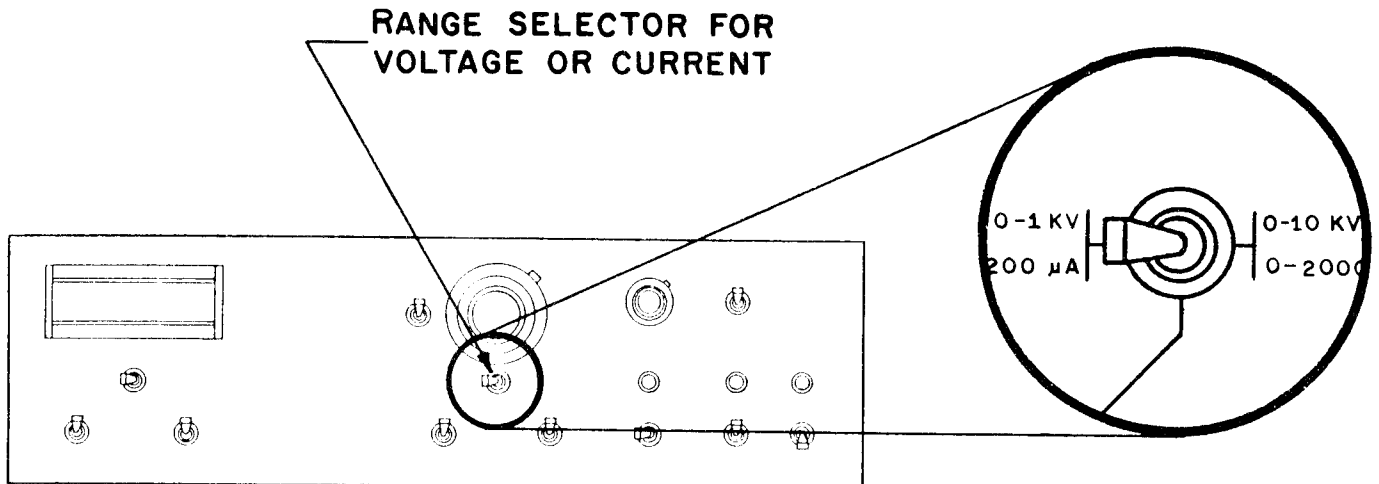

Figure 22. $\mu\text{A}/\text{KV}$ Range Selector Switch

2.1.1.4.5 Polarity Selector Switch

With the “+/-/OFF” polarity switch you can select (see Figure 23):

- a. No output voltage or currents are produced respectively when this switch is in the OFF position and the 610B is functioning as a voltage or current supply; nor offset voltages and currents when the 610B is in the amplifier or controller modes.
- b. Either positive (+) or negative (-) output voltages or currents, I_t or I_r , when the 610B is functioning as a voltage or current supply.
- c. Either no output offset voltage, or (+) or (-) offset voltage when the 610B is functioning as a voltage amplifier or voltage controller.
- d. Either no load offset currents, I_t or I_r , or (+) or (-) load offset currents, I_t or I_r , when the 610B is functioning as a transconductance amplifier or current controller.

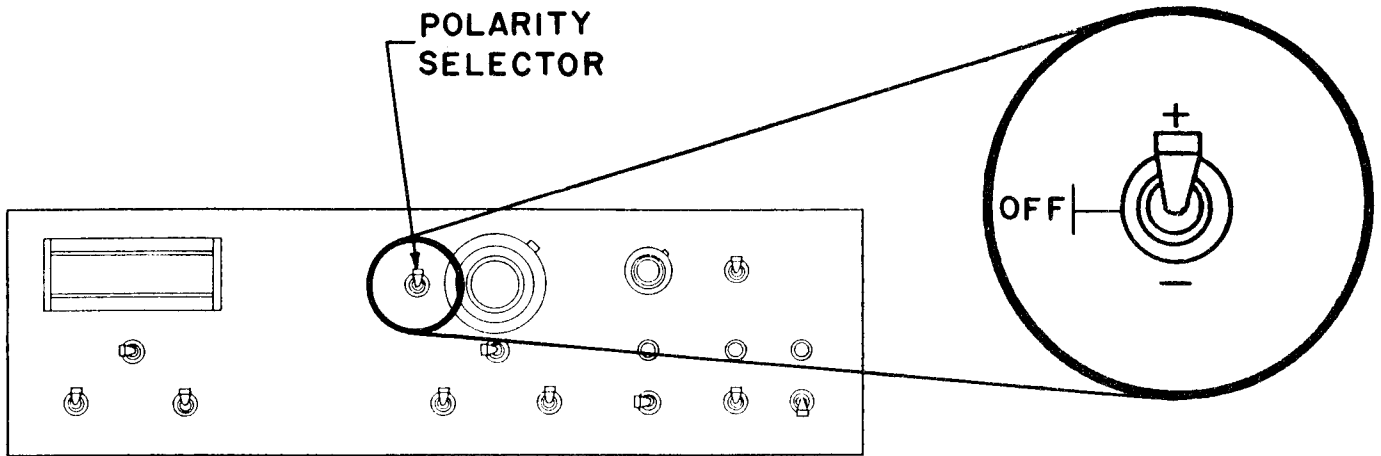

Figure 23. Polarity Selector Switch

2.1.1.5 METER Section

The digital panel meter (DPM) in this section is a 3-1/2-digit DC meter (see Figure 24). The DPM full scale range is selected by the "0 - 1 KV, 0 - 200 μ A"/"0 - 10 KV, 0 - 2000 μ A" range switch. The output voltage is indicated when the V/I switch is in the "V" position. The load current is indicated when the V/I switch is in the "I" position. The I_1/I_2 switch determines which current is indicated when the V/I switch is in the "I" position.

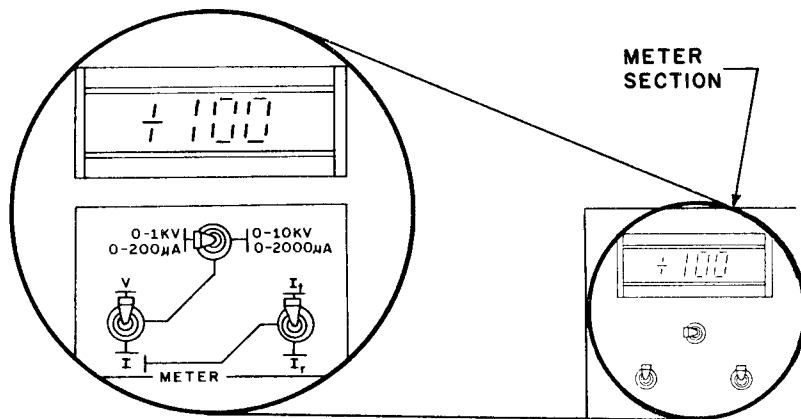

Figure 24. METER Section Controls

2.1.2 Rear Panel

The rear panel has one selector switch and nine connection ports (see Figure 25).

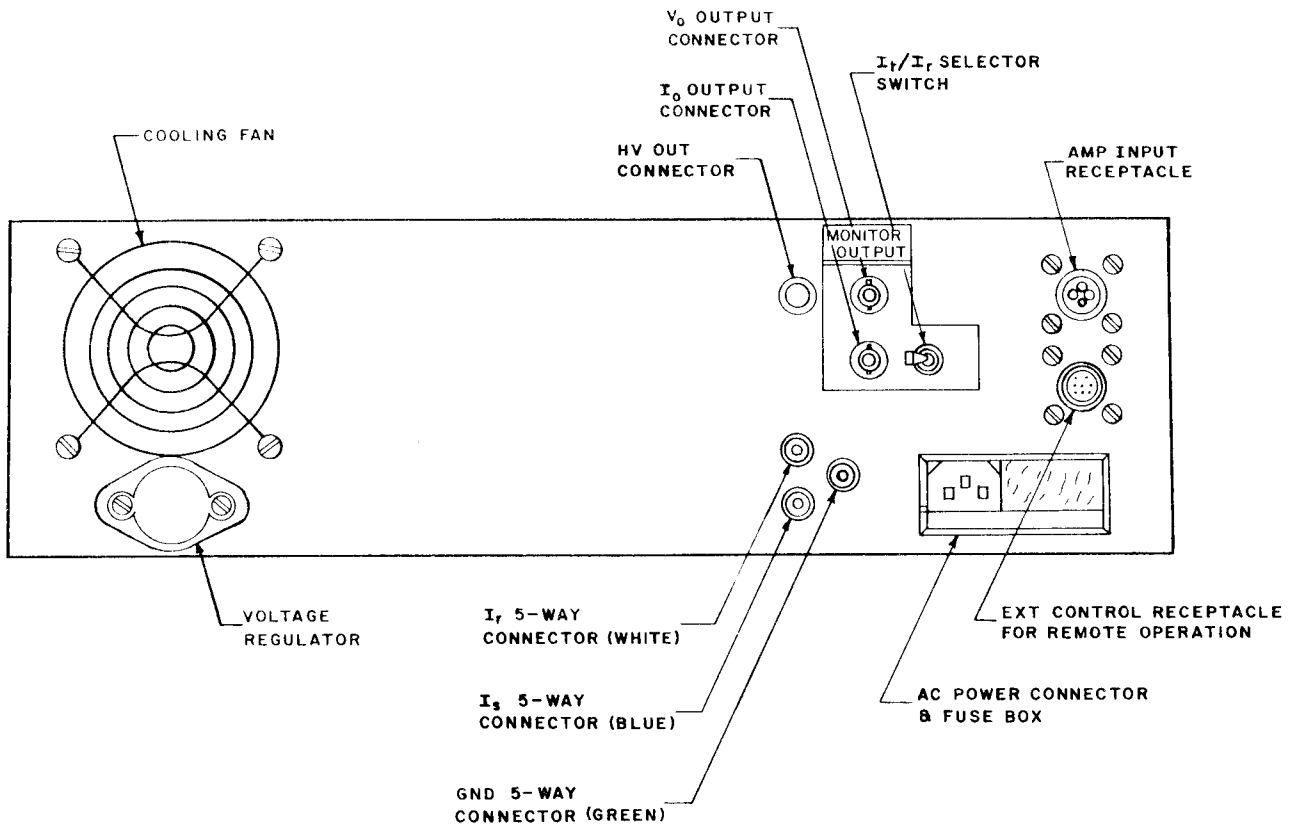

Figure 25. Rear Panel Controls

WARNING

Make no attempt to bypass the ground feature in the power cable. This is a safety feature and any attempt to negate it can result in an injury to the user and/or damage to the equipment.

2.1.2.1 AC Power Cord Receptacle and Fuse Box

The AC power cord receptacle is a standard three-prong connection (see Figure 26). The 1-amp slo-blo fuse is installed at the factory. The 1-amp fuse is recommended for use with 100V and 115V, and a 1/2-amp fuse is recommended for use with 220V inputs (not furnished).

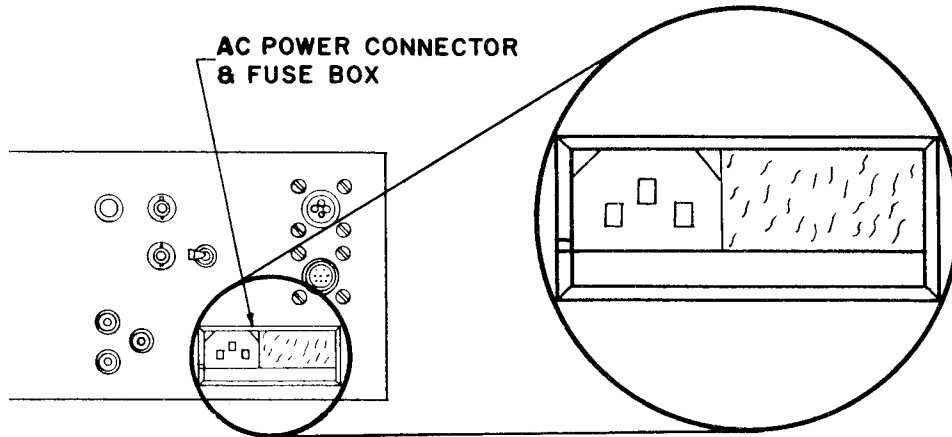

Figure 26. AC Power Cord Receptacle and Fuse Box

2.1.2.2 Remote Control Receptacle

A switch (single pole, normally open) connected between pin 3 and pin 6 of the EXT. CONTROL connector can be used for remote operation of the 610B. This is a 5 V level to ground. The front panel HV switch must be in the REMOTE position for this external switch to operate.

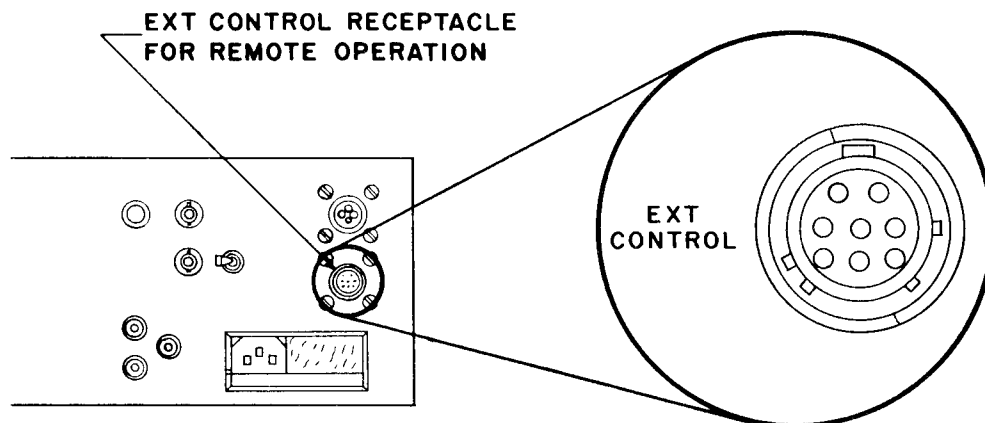

Figure 27. Remote Control Receptacle

2.1.2.3 AMP INPUT Receptacle

The AMP INPUT receptacle is to connect an external signal to the 610B (see Figure 28):

- a. Noninverting operation — input signal to pin 1, common to pin 3, short pins 2 and 3.
- b. Inverting operation — input signal to pin 2, common to pin 3.
- c. Differential operation — input signal between pins 1 and 2, common to pin 3.

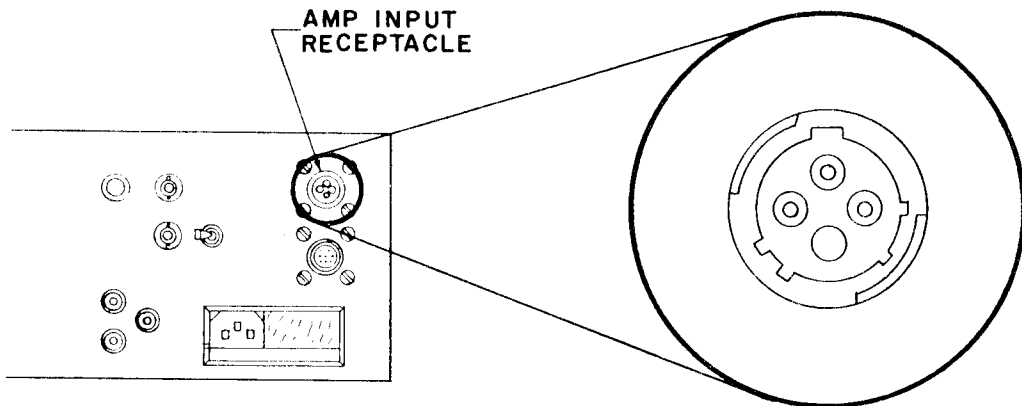

Figure 28. AMP INPUT Receptacle

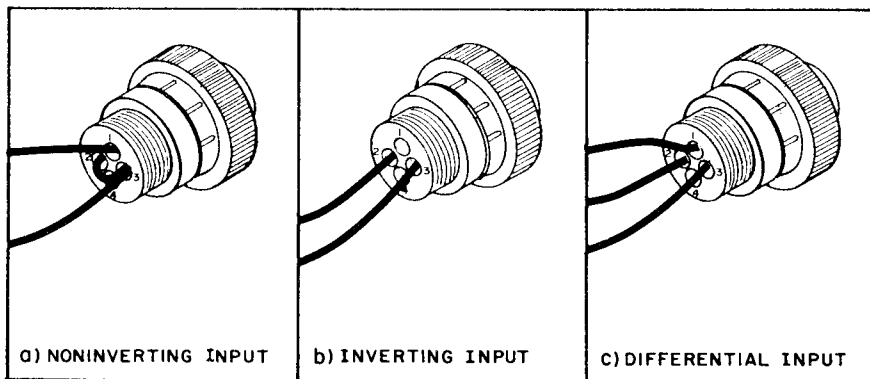

Figure 29. Pin Connections

2.1.2.4 OUTPUT Section

The OUTPUT section has two BNC receptacles, V_o and I_o , and an I_v/I_r selector switch. These receptacles and switch are for your convenience in the use of other read-out equipment, i.e., printers.

2.1.2.4.1 V_o MONITOR OUTPUT Connector

The V_o MONITOR OUTPUT connector is a BNC outlet for monitoring the 610B output voltage at a ratio of 1,000 to 1 ($10\text{ KV} = 10\text{ V}$) (see Figure 30).

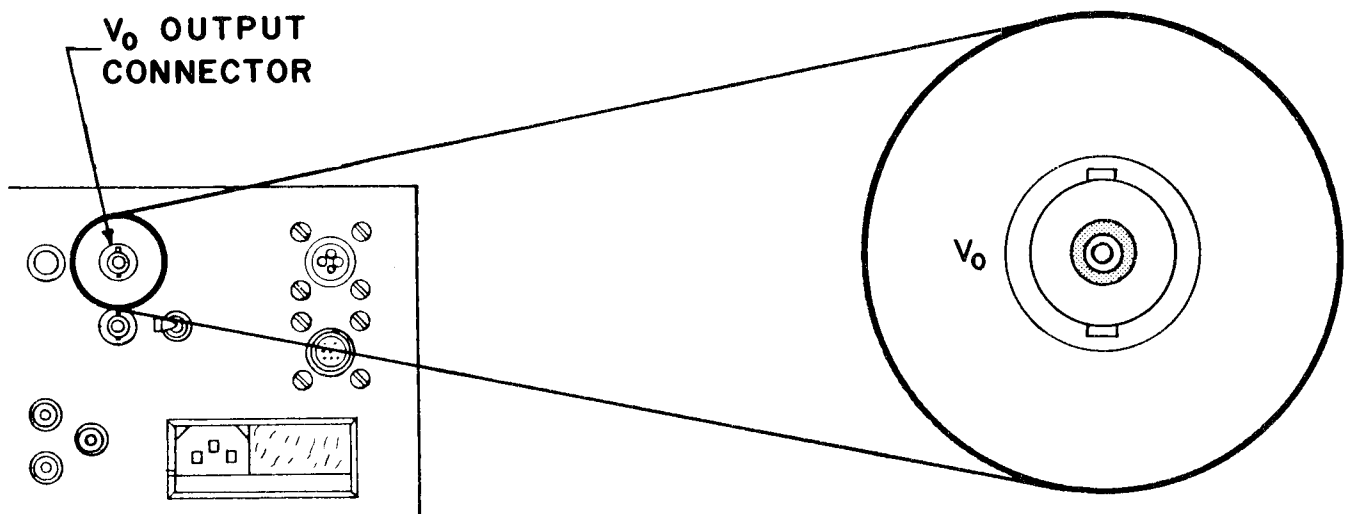

Figure 30. V_o MONITOR OUTPUT Connector

2.1.2.4.2

I_0 MONITOR OUTPUT Connector

The I_0 MONITOR OUTPUT connector is a BNC outlet for monitoring I_t/I_r (2000 μ A equals 10 V FS of I_t or I_r current) (see Figure 31).

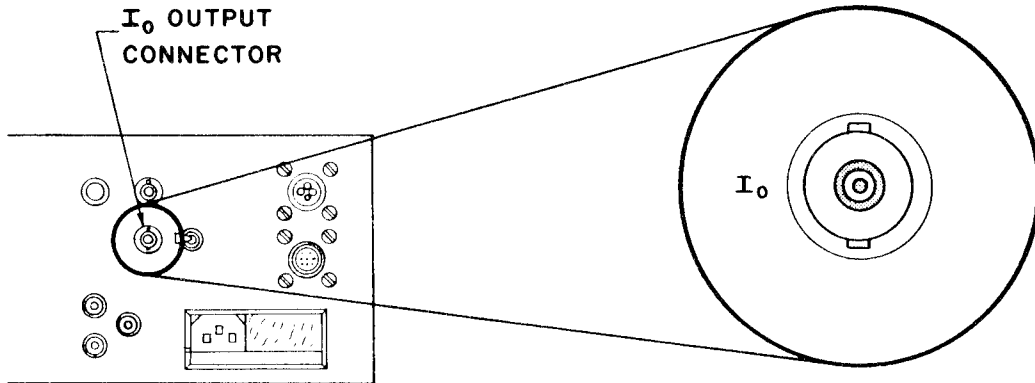

Figure 31. I_0 MONITOR OUTPUT Connector

2.1.2.4.3

I_t/I_r Monitor Selector Switch

The I_t/I_r switch selects which current, I_t or I_r , is to be monitored at the I_0 monitor connector (see Figure 32).

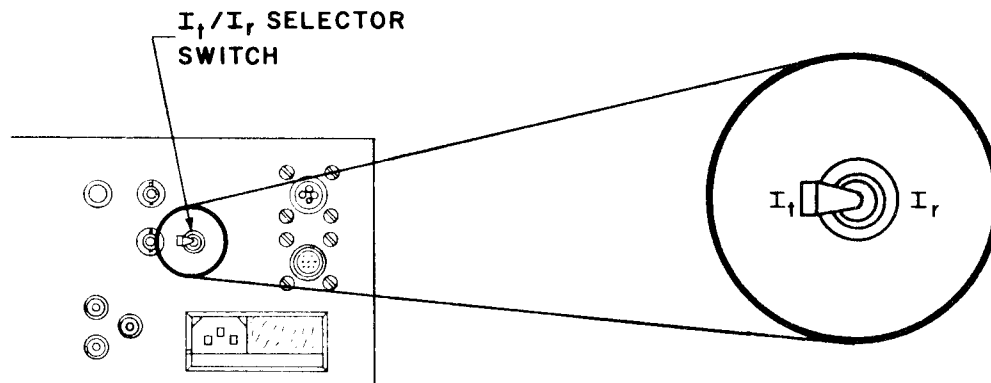

Figure 32. I_t/I_r Monitor Selector Switch

2.1.2.5 HV OUT

The HV OUT connector is for output load connection (see Figure 33).

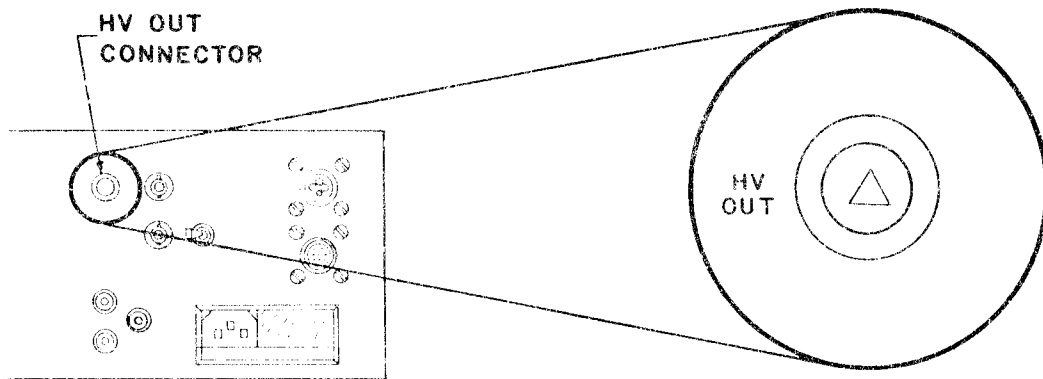

Figure 33. HV OUT Connector

2.1.2.6 Ground Connector

The ground connector, a green, 5-way connector, connects to chassis ground and is used for output load ground termination (see Figure 34).

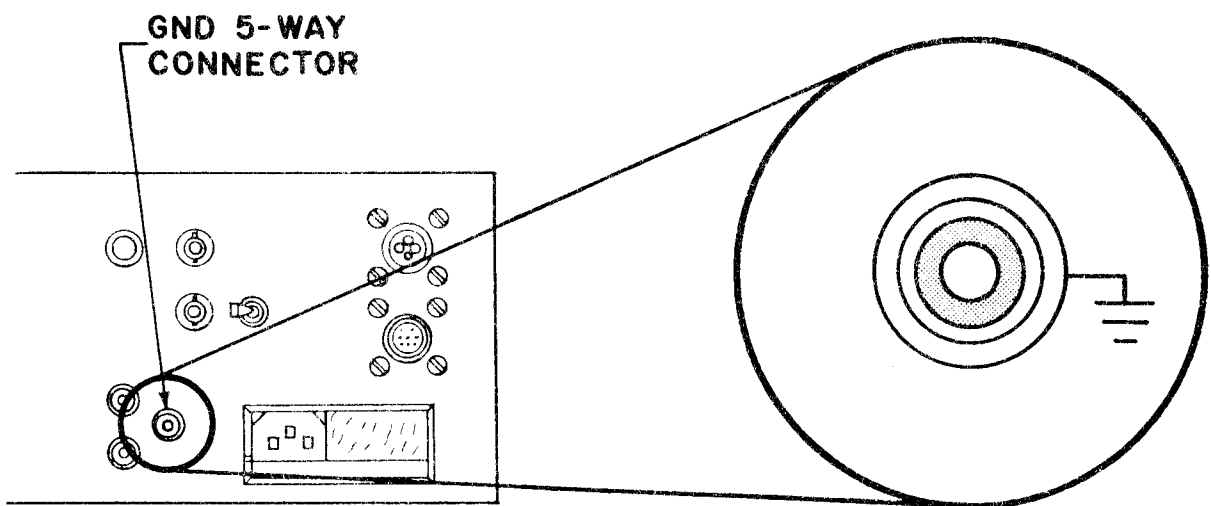

Figure 34. Ground Connector

2.1.2.7 I_r Connector

The I_r connector, a white, 5-way connector, is used for terminating the output load when operating the 610B in the I_r mode (see Figure 35).

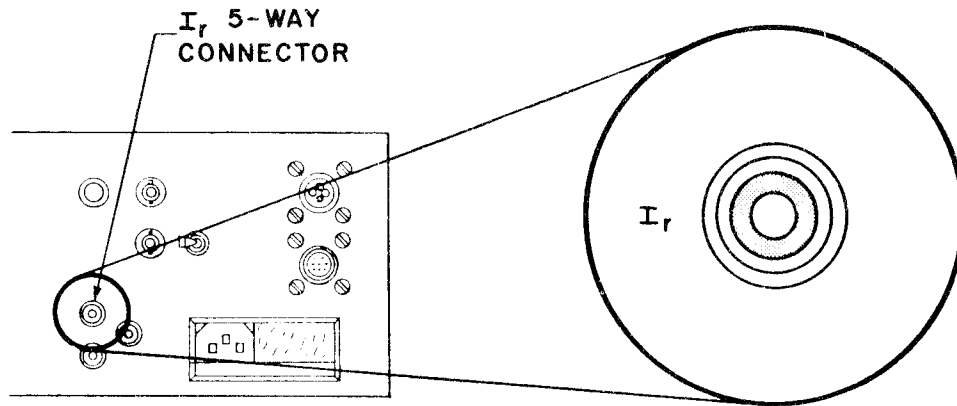

Figure 35. I_r Connector

2.1.2.8 I_s Connector

The I_s connector, a blue, 5-way connector, provides a termination for electrophotographic Coratron shielding electrodes connected to the 610B (see Figure 36). When this connection is used, any current flowing to the I_s connector is not measured and controlled while operating in the I_t mode. In this mode, I_t becomes a true measure of electrophotographic surface current and can be controlled to high accuracy by the 610B, thereby providing electrophotographic surface current regulation into grounded surfaces.

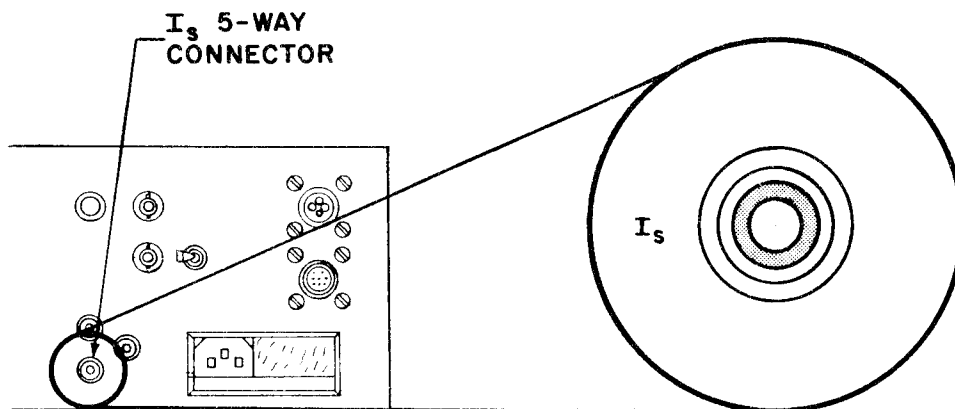

Figure 36. I_s Connector

2.2 ROUTINE OPERATION

The 610B can operate in three modes with a great many variations within those three modes. The modes are: SUPPLY, AMPLIFIER, and CONTROLLER. Random control values were chosen to illustrate a routine operation in each mode, and are to be used as a guide only.

2.2.1 Supply Mode

In the SUPPLY position, the 610B can function either as a voltage supply with an adjustable current limit, or as a current supply with an adjustable voltage limit.

2.2.1.1 Voltage Supply With Adjustable Current Limit

As a precise, adjustable power supply, the 610B has an adjustable current limit. To set the 610B to function as a voltage supply:

- a. Ensure the POWER switch and the HV switch are set to OFF (see Figure 37).

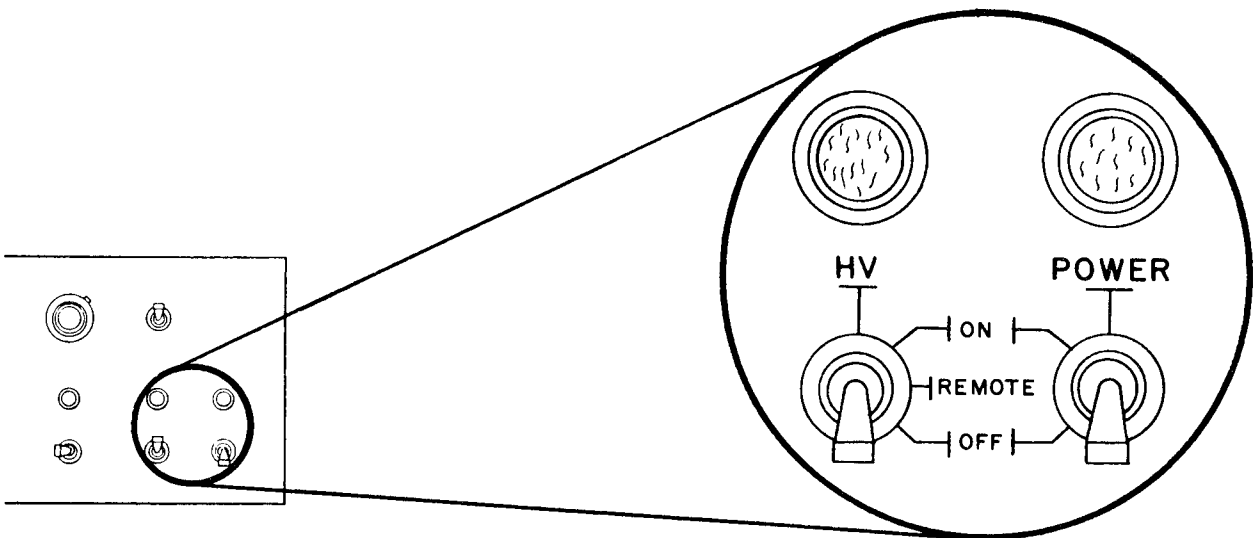

Figure 37. POWER and HV Switches Set to OFF

- b. At the rear panel, make the connections (see Figure 38):
- 1) From HV OUT to the load
 - 2) Return from the load to ground (green receptacle)

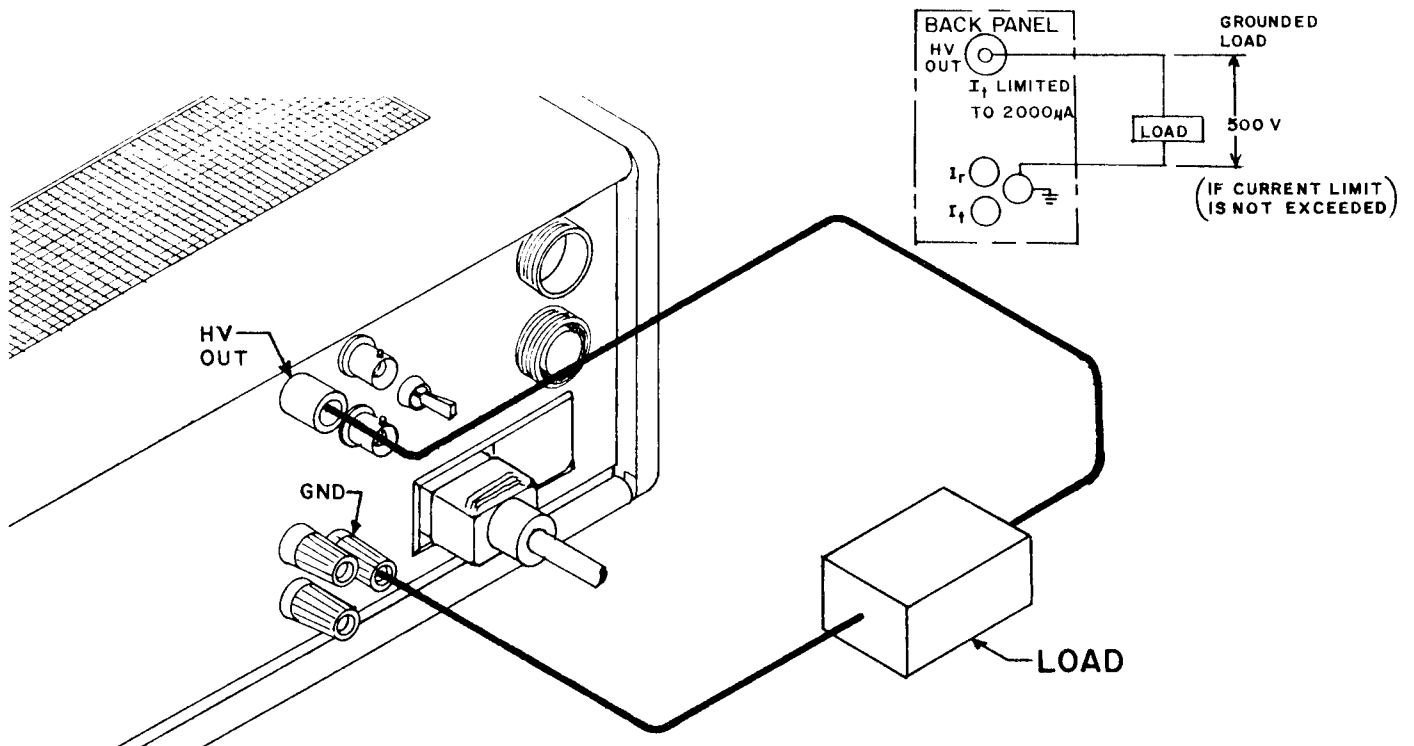

Figure 38. Example of Rear Panel Connections

- c. Plug the female connector on the AC power cord into the AC power receptacle on the rear panel of the 610B (see Figure 39).

WARNING

Make no attempt to bypass the ground feature in the power cable. This is a safety feature and any attempt to negate it can result in an injury to the user and/or damage to the equipment.

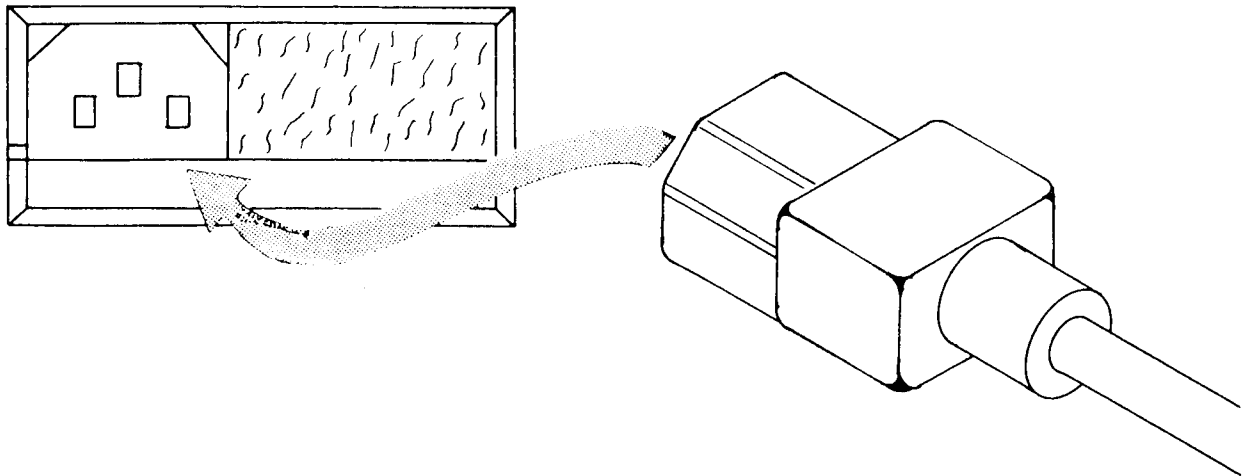

Figure 39. Plug Power Cord Into 610B Receptacle

- d. Plug the power cord into a power source (see Figure 40).

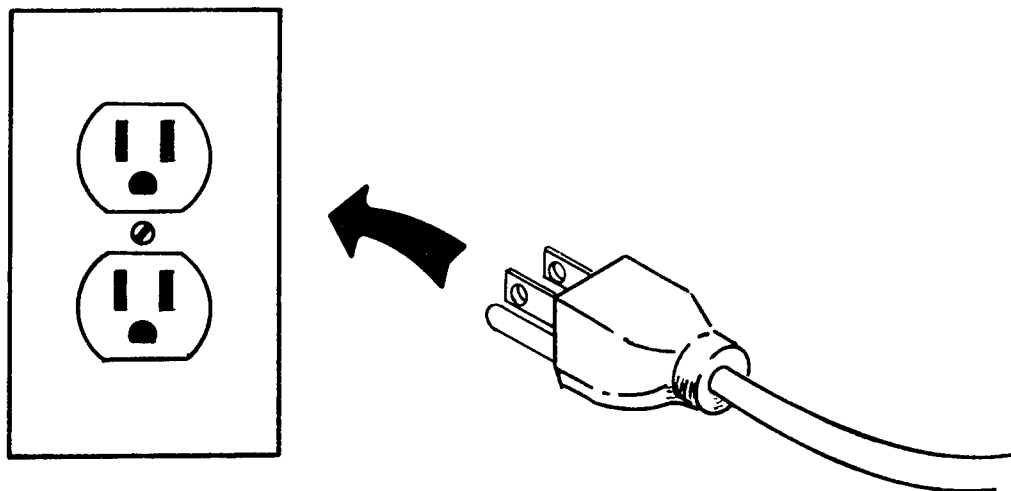

Figure 40. Plug Power Cord Into Power Source

e. To perform a routine operation in the SUPPLY mode, given a random value of + 500 V, set the controls as follows (see Figure 41):

- | | | |
|----|--------------------|---|
| 1) | Mode: | V |
| 2) | Polarity: | + |
| 3) | Range: | 0 - 1 KV |
| 4) | Command: | 500 V |
| 5) | Compliance limit: | 100 (maximum setting)
limits I_t to $\pm 2000 \mu A$ |
| 6) | Compliance select: | I_t |
| 7) | DPM monitor: | voltage |
| 8) | Meter range: | 0 - 1 KV |

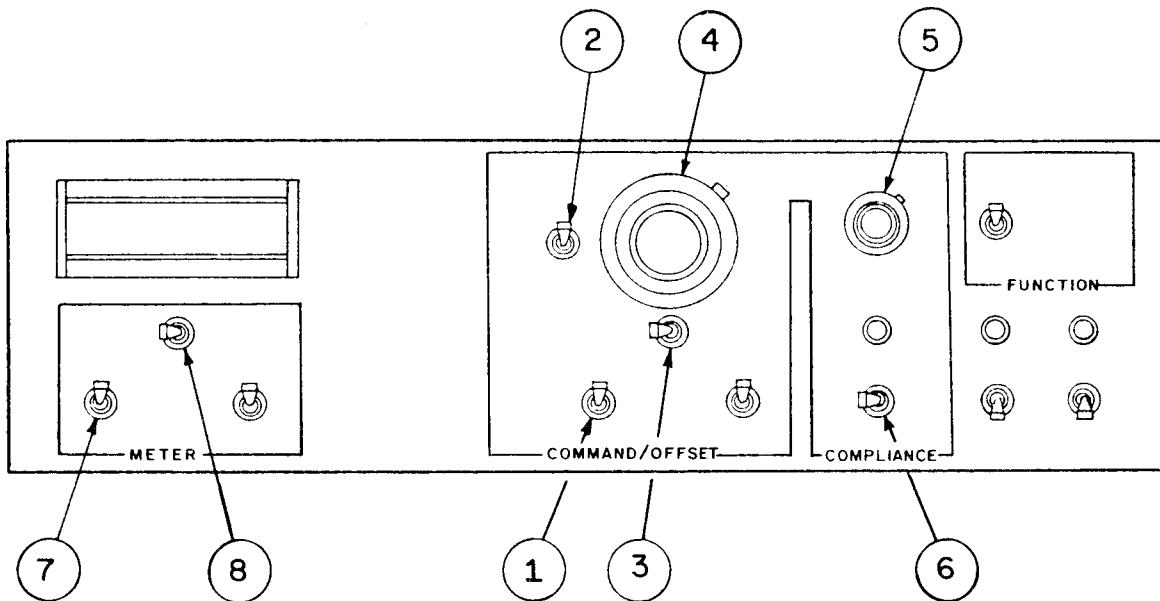

Figure 41. Example of Front Panel Settings

- f. On the front panel, flip the POWER switch to the ON position (see Figure 42).

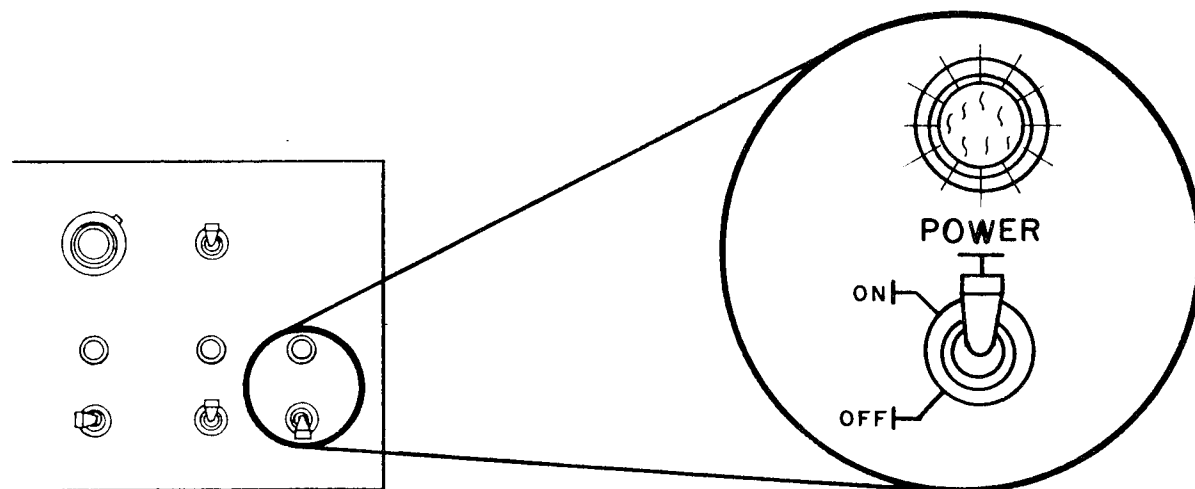

Figure 42. POWER Switch to ON

- g. Wait thirty seconds after the POWER switch has been set to ON, then flip the HV switch to ON (see Figure 43). The DPM displays the magnitude of voltage between HV OUT and ground.

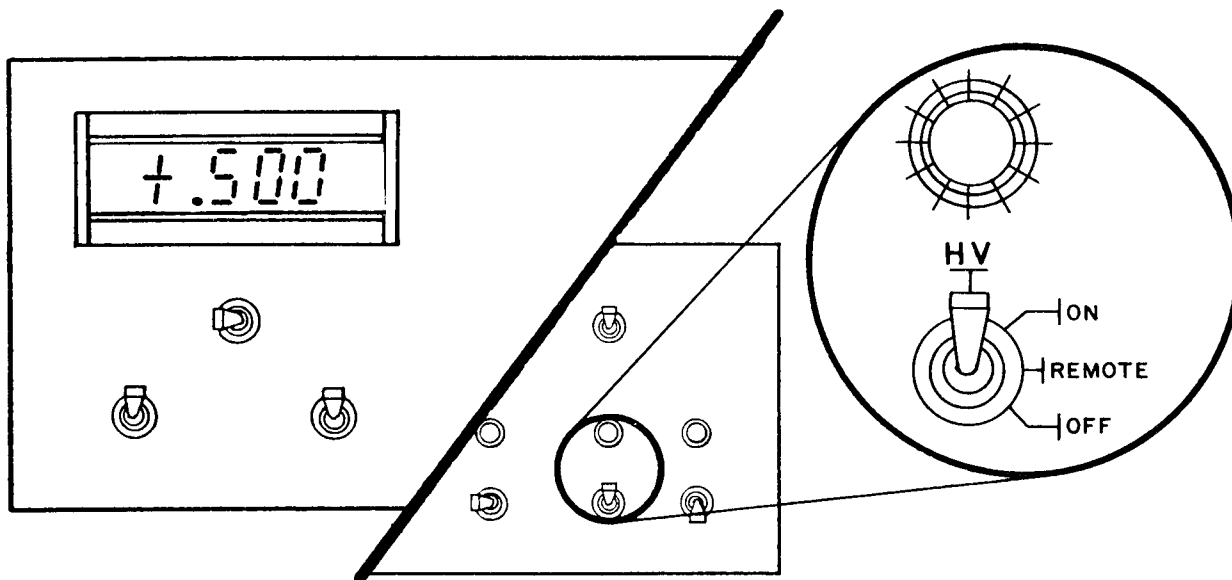

Figure 43. HV Switch to ON

NOTE

If the load condition is such that you are attempting to draw more current from the 610B than that set by the limit, then the output voltage is restricted.

EXAMPLE

With a set-up of the current limit set at the maximum 2000 μA and the supply voltage set at 500 V

For a resistive load of 300 kilohms:

1667 μA flows through the load

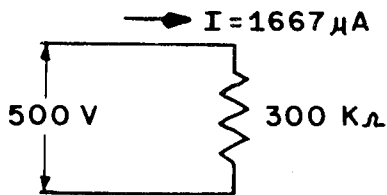

$$I = \frac{V}{R} = \frac{500 \text{ V}}{300 \text{ k}\Omega} = 1667 \mu\text{A}$$

With the same set-up

For a 200 kilohms load:

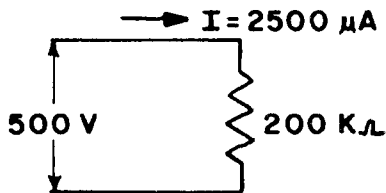

$$I = \frac{V}{R} = \frac{500 \text{ V}}{200 \text{ k}\Omega} = 2500 \mu\text{A}$$

The current is limited by the compliance function set to a maximum of 2000 μA .

Therefore the voltage at the HV OUT terminal is restricted to 400 V while 2000 μA is supplied.

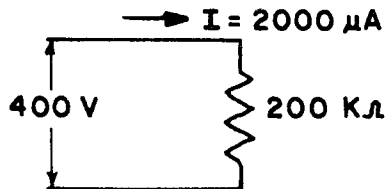

$$V = IR = (2000 \mu\text{A}) 200 \text{ k}\Omega = 400 \text{ V}$$

2.2.1.2 Current Supply With Adjustable Voltage Limit

In the current SUPPLY mode, the controlled current may be either the total output current measured at the HV OUT terminal (I_t total current), or the current returning to the I_r terminal (returned current).

2.2.1.2.1 Current Supply I_r Regulated

Control of the I_r is useful if you want to regulate a single, ungrounded current path in the presence of multiple loads on the output of the 610B. If I_r is the controlled quantity, this current must be returned into the white I_r terminal on the rear panel.

The setup for operation in this mode with a given set of random values is as follows:

- a. Ensure the POWER switch and the HV switch are set to OFF (see Figure 44).

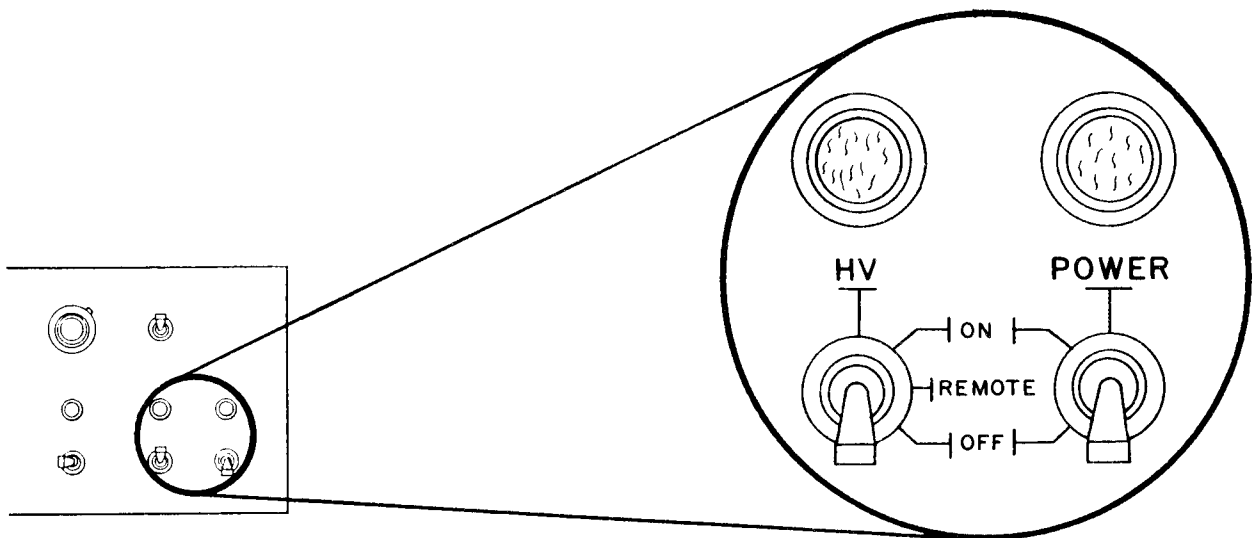

Figure 44. POWER and HV Switches to OFF

b. At the rear panel, make the connections (see Figure 45):

- 1) From the HV OUT receptacle to the load.
- 2) Return the load to the I_r receptacle.

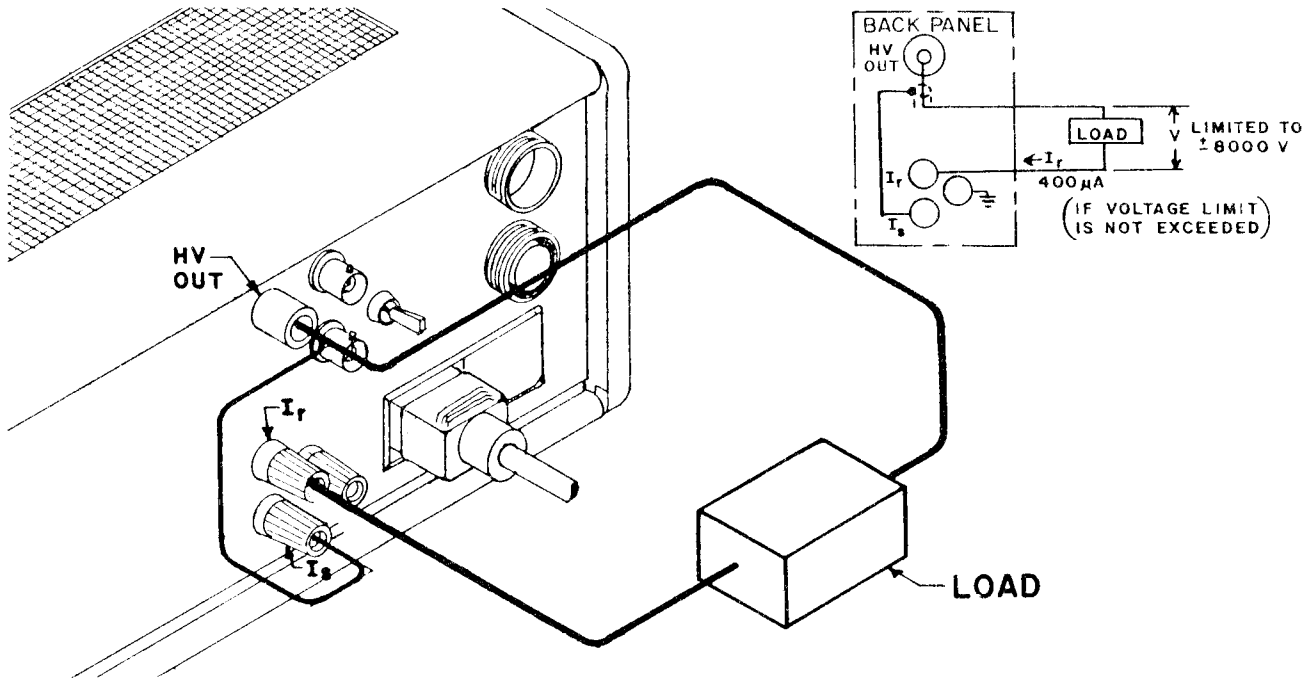

Figure 45. Sample Rear Panel Hook-up I, Regulated

c. Plug the female connector on the AC power cord into the AC power receptacle on the rear panel of the 610B (see Figure 46).

WARNING

Make no attempt to bypass the ground feature in the power cable. This is a safety feature and any attempt to negate it can result in an injury to the user and/or damage to the equipment.

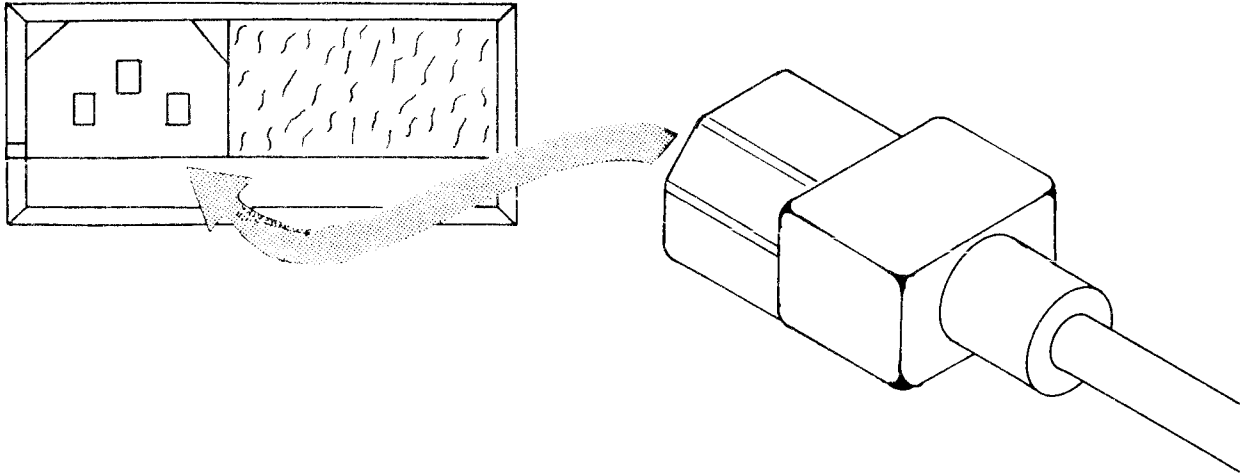

Figure 46. Plug Power Cord Into 610B Receptacle

- d. Plug the power cord into a power source (see Figure 47).

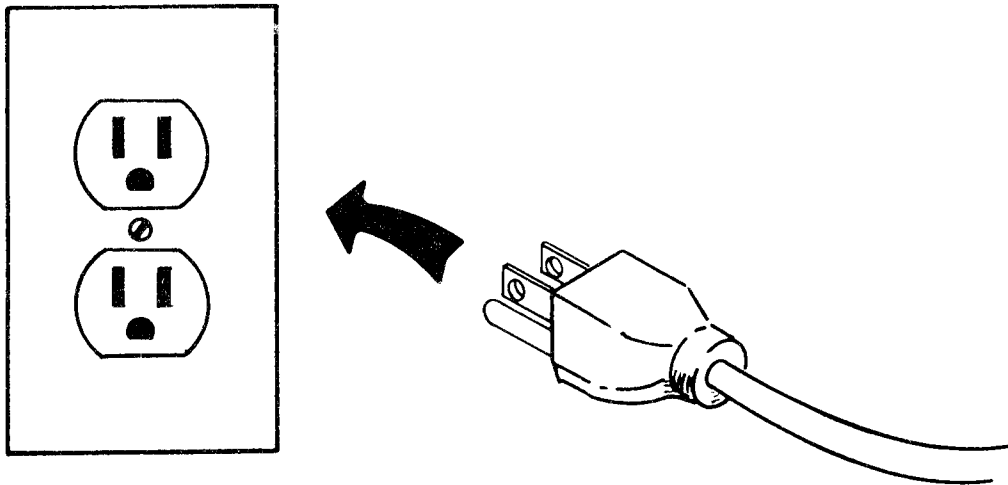

Figure 47. Plug Power Cord Into Power Source

e. To perform a current operation in the I_r SUPPLY mode, given a random value of $+400 \mu\text{A}$, set the controls as follows (see Figure 48):

- | | | |
|-----|----------------------|---|
| 1a) | Controlled quantity: | I |
| 1b) | | I_r |
| 2) | Polarity: | $+$ |
| 3) | Range: | $0 - 2000 \mu\text{A}$ |
| 4) | Command: | 20 ($400 \mu\text{A}$) |
| 5) | Compliance limit: | 80 ($\pm 8000 \text{ V}$, limiting the voltage output at the HV OUT connector.) |
| 6a) | DPM monitor: | I (current) flowing through 6b |
| 6b) | | I_r terminal |
| 7) | Meter range: | $0 - 2000 \mu\text{A}$ |

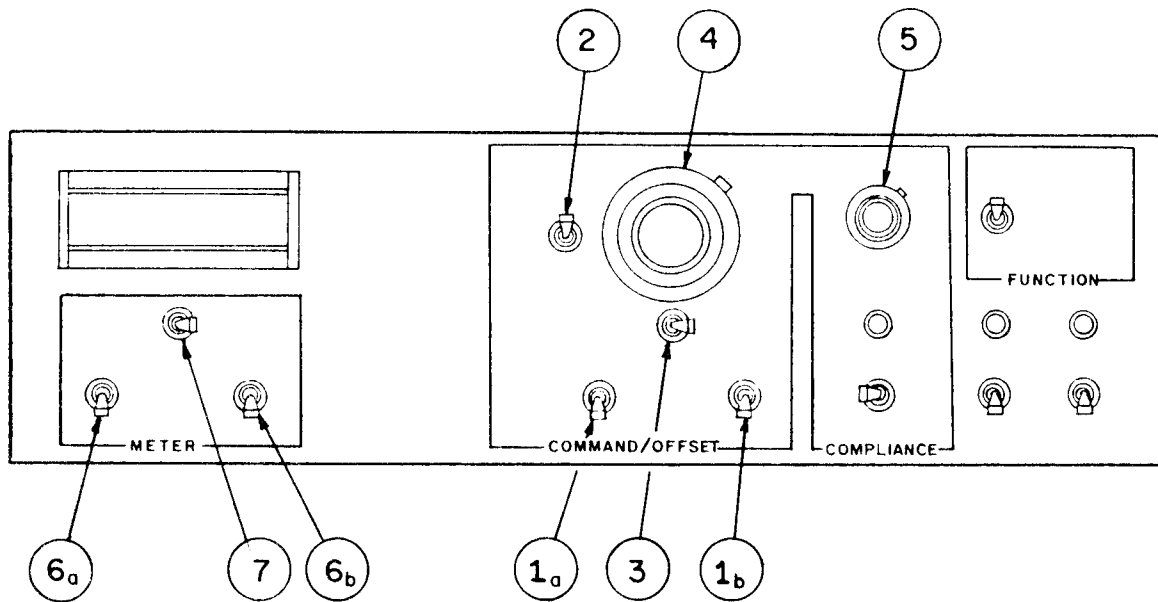

Figure 48. Example of Front Panel Settings

NOTES

1) Current SUPPLY I_t and I_r

If the load condition is such that you are attempting to exceed the voltage compliance limit, then the output current is restricted to produce the compliance voltage limit value.

EXAMPLE

For a resistive load of	22.5 M ohms
Voltage limit set at	8000 V
Supply current set at	400 μ A

To supply 400 μ A to a 22.5 M ohms load would require 9000 V.

$$V = IR = (400 \mu\text{A}) (22.5 \text{ M ohms}) = 9000 \text{ V}$$

but the voltage available at the HV OUT receptacle is limited to 8000 V by the compliance function setting, therefore only 356 μ A would be supplied to the load.

$$I = \frac{V}{R} = \frac{8000\text{V}}{22.5 \text{ M ohms}} = 356 \mu\text{A}$$

2) When attempting to control current in an open path, no current will flow and the voltage across that path will be limited to the voltage value of the compliance function setting.

f. On the front panel, flip the POWER switch to ON (see Figure 49).

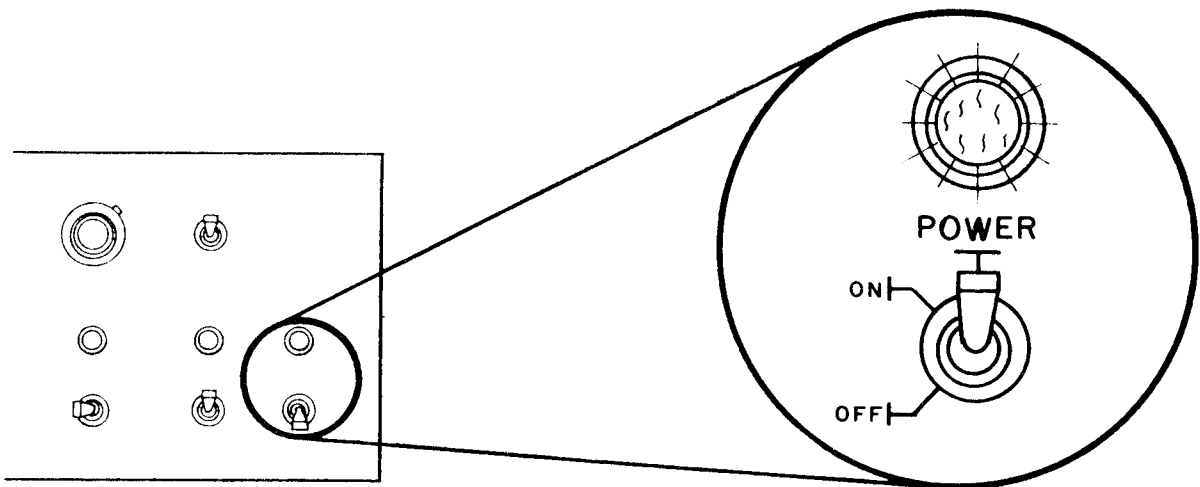

Figure 49. POWER Switch to ON

g. Wait thirty seconds after the POWER switch has been set to ON, then flip the HV switch to ON (see Figure 50). The DPM displays the 400 μ A flowing in the external load if the 8000 V limit is not exceeded.

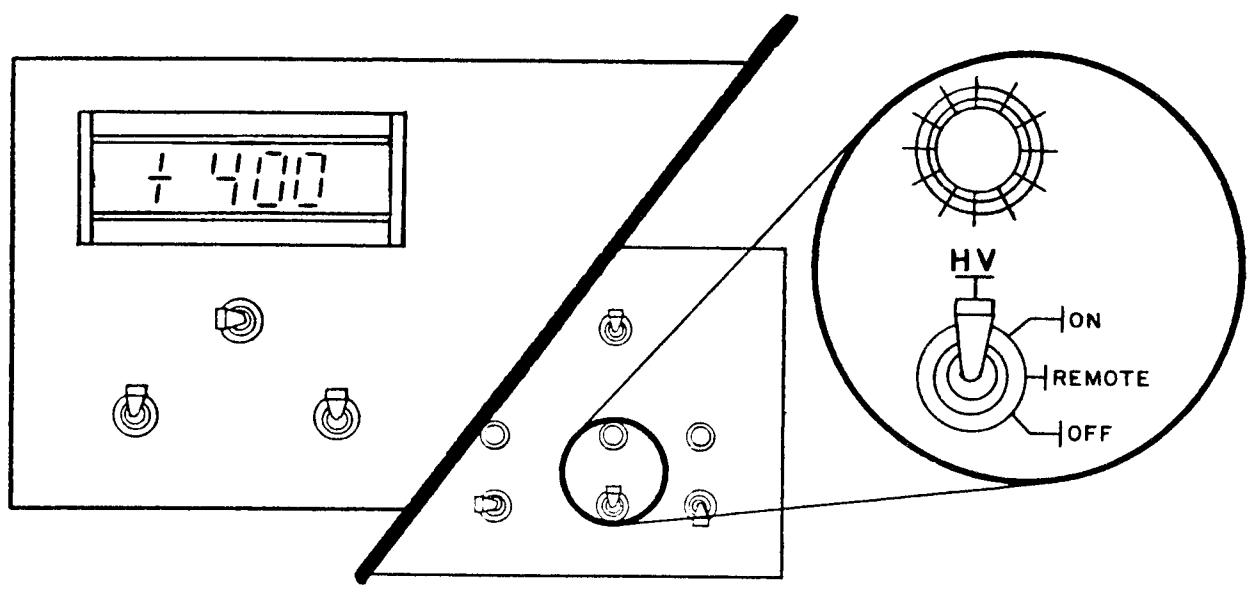

Figure 50. HV Switch to ON

2.2.1.2.2 Current Supply I_t Regulated

If I_t is controlled, the load current can be returned to chassis ground or to the I_t terminal. The I_s terminal on the rear panel allows the return of an unmonitored current path when I_t is the controlled current. The setup for operation in this mode with a given set of random values is as follows:

- a. Ensure the POWER switch and the HV switch are set to the OFF position (see Figure 51).

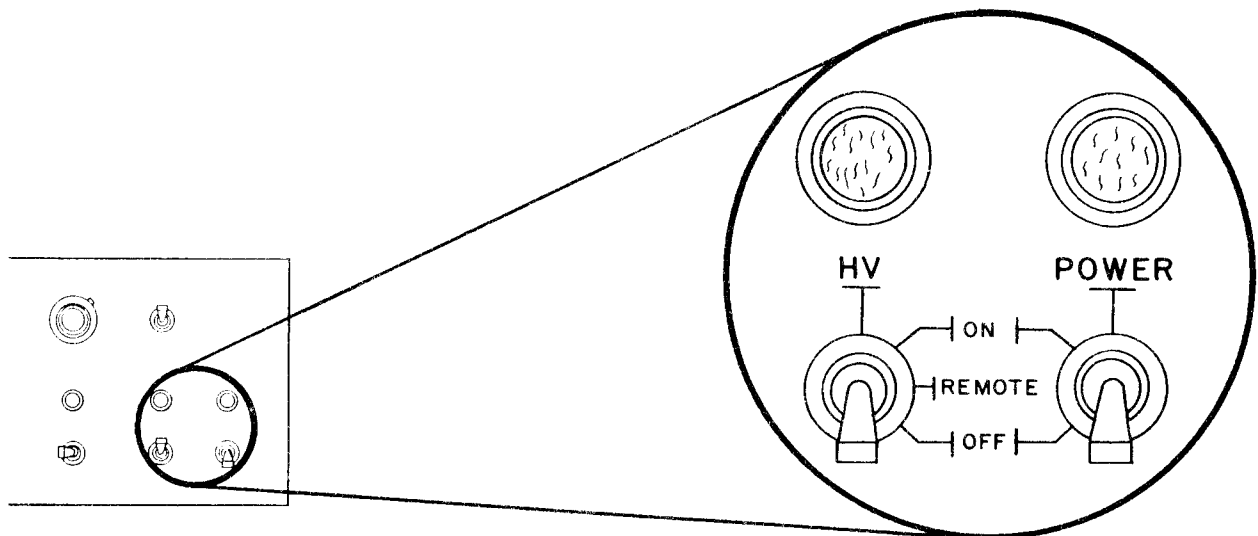

Figure 51. POWER and HV Switches to OFF

- b. At the rear panel, make the connections (see Figure 52):
- 1) Either:
 - A. From the HV OUT receptacle to the load and return to the I_r receptacle.
 - B. Shield line to I_s (if used).
 - 2) Or:
 - A. From the HV OUT receptacle to the load and return to the ground receptacle.
 - B. Shield line to I_s (if used).

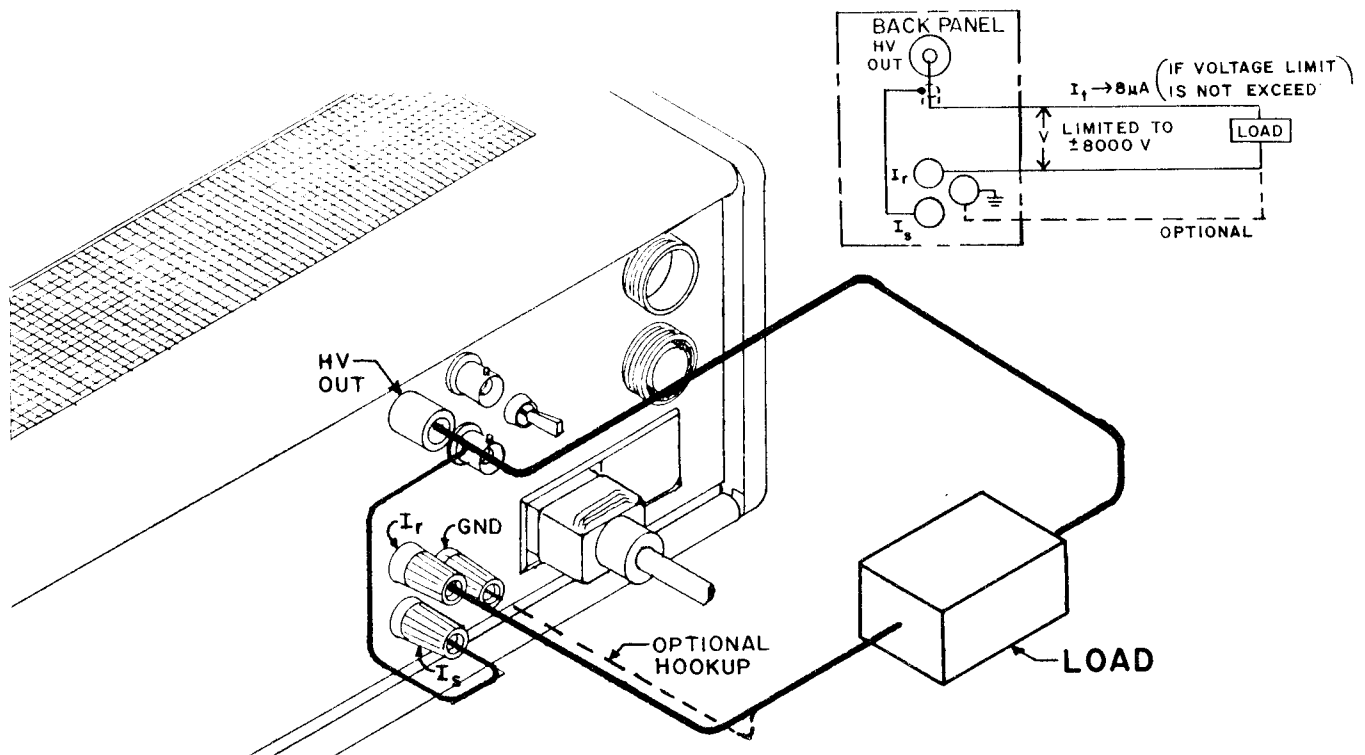

Figure 52. Sample Rear Panel Hook-up I_r Regulated

- c. Plug the female connector on the AC power cord into the AC power receptacle on the rear panel of the 610B (see Figure 53).

WARNING

Make no attempt to bypass the ground feature in the power cable. This is a safety feature and any attempt to negate it can result in an injury to the user and/or damage to the equipment.

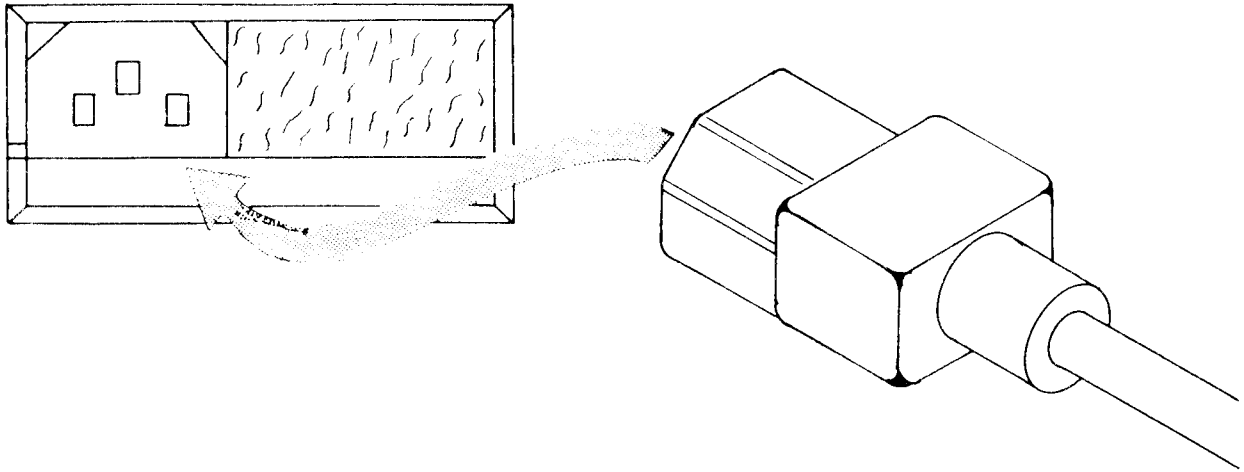

Figure 53. Plug Power Cord Into 610B Receptacle

- d. Plug the power cord into a power source (see Figure 54).

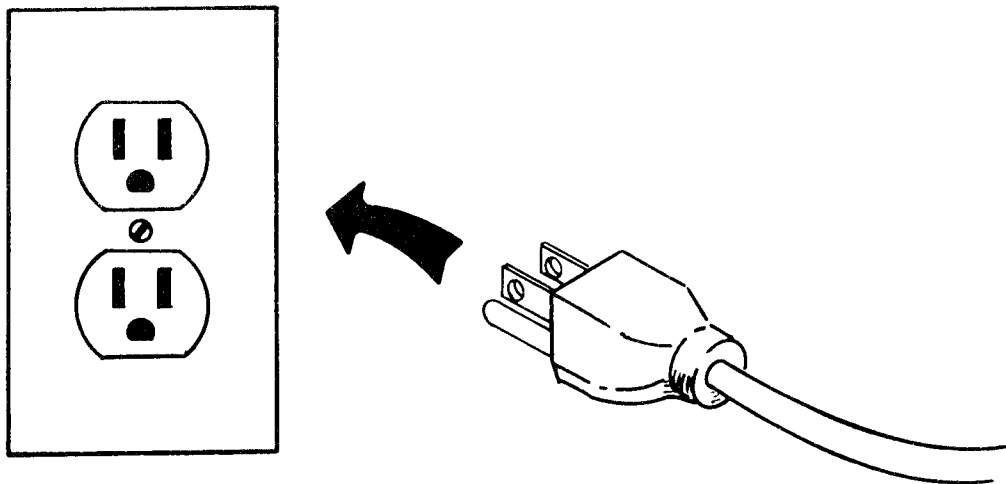

Figure 54. Plug Power Cord Into Power Source

e. To perform a current operation in the SUPPLY mode, given a random value of + 80 μ A, set the controls as follows (see Figure 55):

- | | | |
|-----|-------------------|---|
| 1a) | Mode: | I |
| 1b) | | I ₁ |
| 2) | Polarity: | + |
| 3) | Range: | 0 - 200 μ A |
| 4) | Command: | 40 (80 μ A) |
| 5) | Compliance limit: | 80 (\pm 8000 V, limiting the voltage output at HV OUT connector) |
| 6) | DPM monitor: | voltage |
| 7) | Meter range: | 0 - 1 KV |

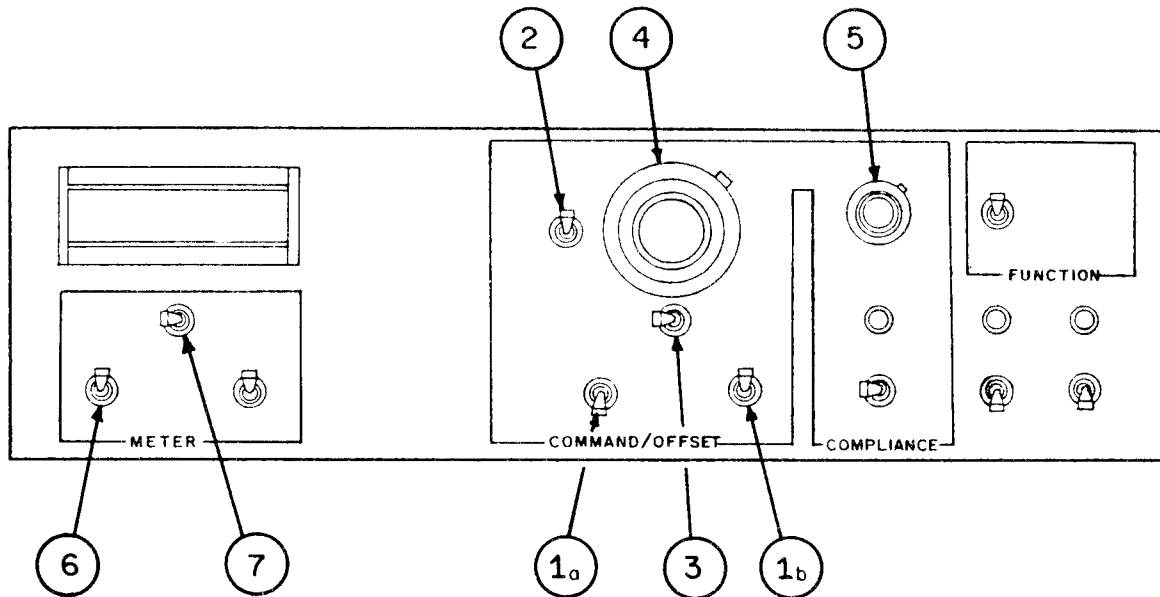

Figure 55. Example of Front Panel Settings

- f. On the front panel, flip the POWER switch to the ON position (see Figure 56).

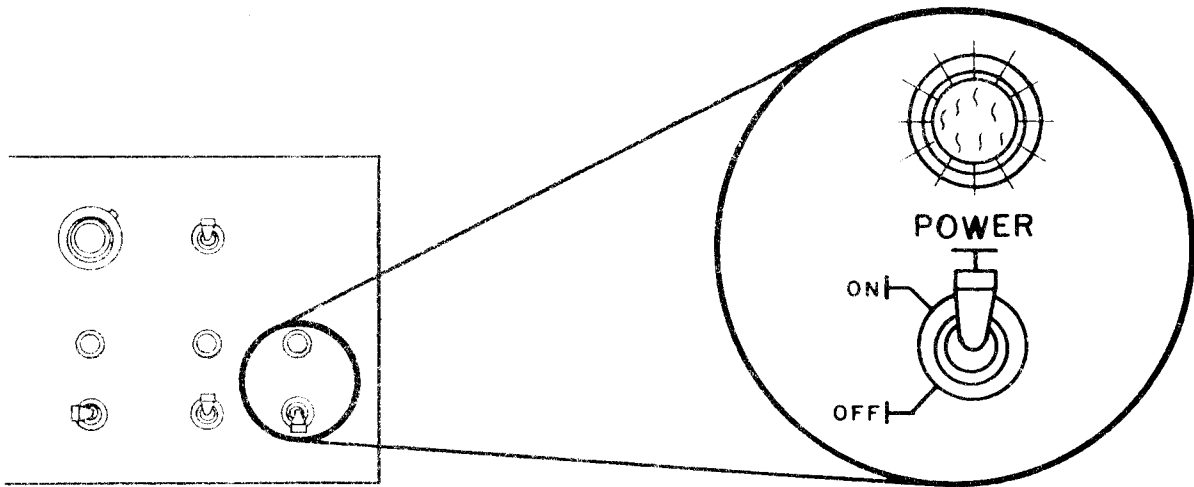

Figure 56. POWER Switch to ON

- g. Wait thirty seconds after the POWER switch has been set to ON, then flip the HV switch to ON (see Figure 57). The DPM displays the voltage across the load.

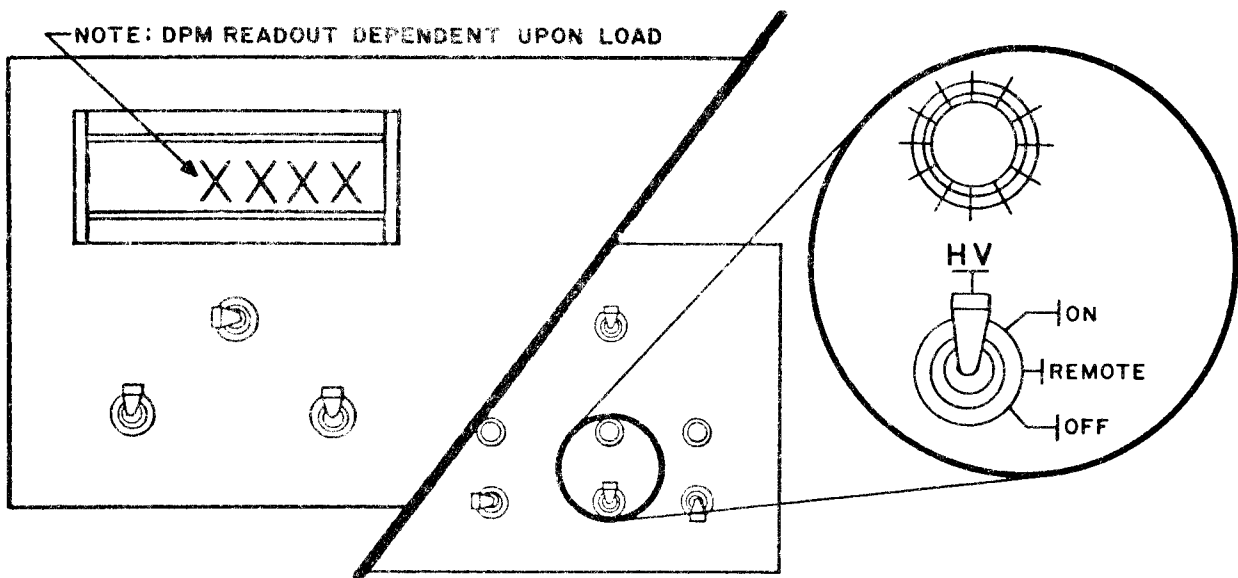

Figure 57. HV Switch to ON

2.2.2 Amplifier Mode

In the AMPLIFIER mode, the 610B has either a selectable, fixed voltage gain of 100V/V or 1000V/V, or it has a selectable, fixed transconductance gain of 20 $\mu\text{A out/V in}$ or 200 $\mu\text{A out/V in}$. In the AMPLIFIER mode, the COMMAND/OFFSET potentiometer dial functions as an offset (+), (-) or OFF command to offset the output voltage or current from zero. The input control signal then varies the output around this offset value.

If I_r is the quantity selected, the current must be returned into the I_r terminal on the rear panel. When I_r is the quantity selected and the current path doesn't include the I_r terminal, the voltage appearing at the HV OUT terminal will go to maximum output voltage set by the compliance limit. If I_v is the quantity selected, the current may be returned to chassis ground or the I_r terminal.

Connect the input signal into the AMP INPUT receptacle on the rear panel (see Figure 58):

- a. noninverting input — input signal to pin 1, common to pin 3, short pins 2 and 3.
- b. inverting input — input signal to pin 2, common to pin 3
- c. differential input — input signal between pins 1 and 2, common to pin 3.

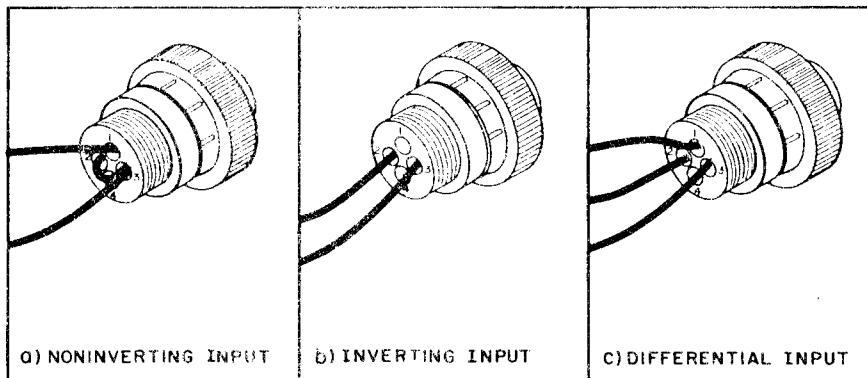

Figure 58. Pin Connections for Input Variations

2.2.2.1 Voltage Amplifier

As a voltage amplifier the gain is selectable and switch fixed:

- a. 100 V/V when the range switch in the COMMAND/OFFSET section is in the "0 - 1 KV" position.
- b. 1000 V/V when the range switch in the COMMAND/OFFSET section is in the "0 - 10 KV" position.

The output offset voltage is set by the potentiometer dial in the COMMAND/OFFSET section. When the range is switched to "0 - 1 KV" then each division equals one volt. When the range is switched to "0-10 KV" then each division equals 10 volts.

The potentiometer dial in the COMPLIANCE section lets you limit either I_t or I_r by setting that switch in the desired position and adjusting the ten-turn, 500-division potentiometer. Each division equals $4 \mu\text{A}$, with a range of $20 \mu\text{A}$ to $2000 \mu\text{A}$.

The setup for operation in this mode with a given set of random values is as follows:

- a. Ensure the POWER switch and the HV switch are set to OFF (see Figure 59).

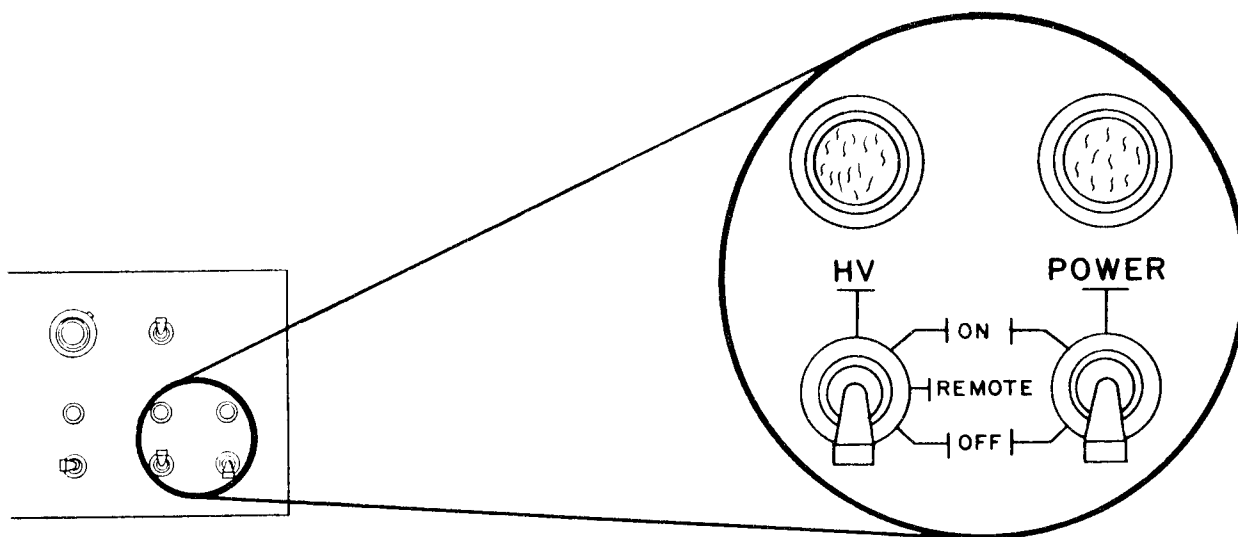

Figure 59. POWER and HV Switches to OFF

b. At the rear panel, make the connections (see Figure 60):

- 1) From HV OUT to the load.
- 2) Return the load to ground (green receptacle).

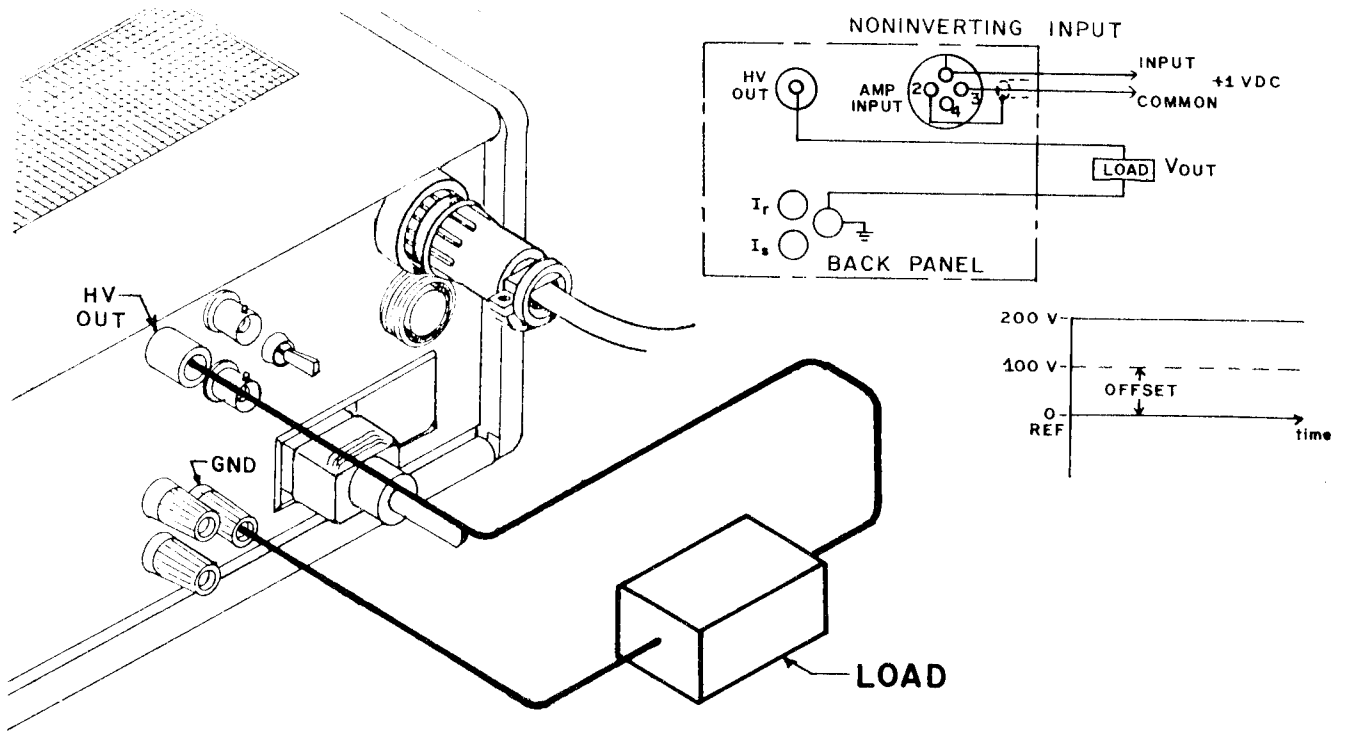

Figure 60. Example of Rear Panel Connections

- c. Plug the female connector on the AC power cord into the AC power receptacle on the rear panel of the 610B (see Figure 61).

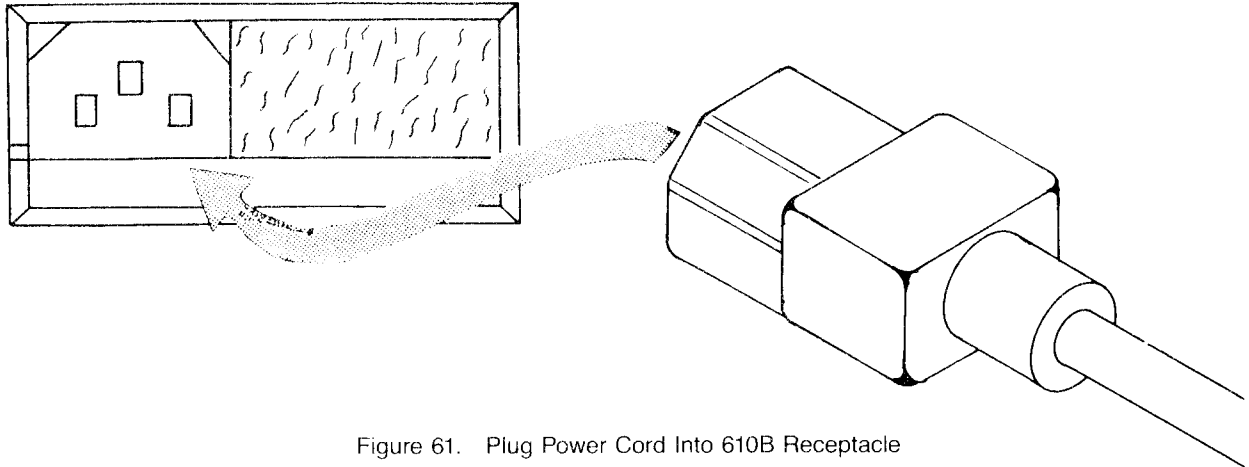

Figure 61. Plug Power Cord Into 610B Receptacle

- d. Plug the power cord into a power source (see Figure 62).

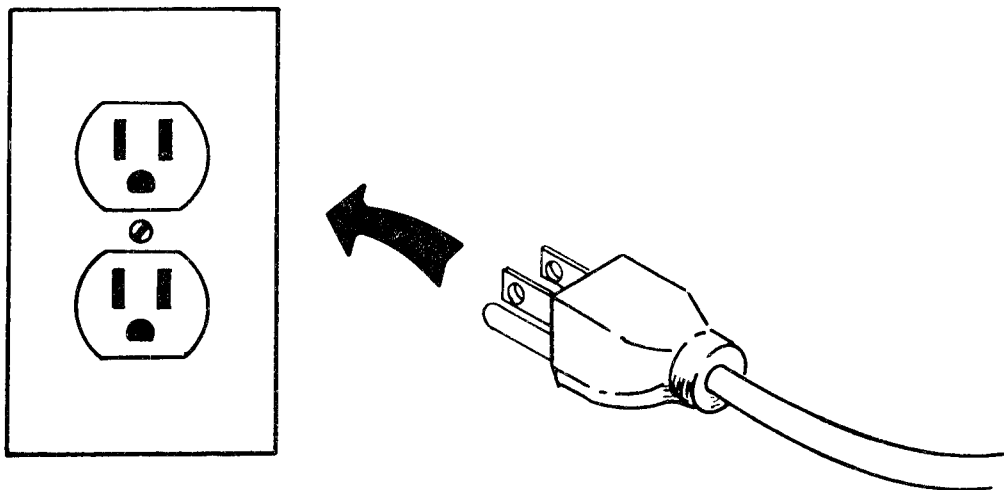

Figure 62. Plug Power Cord Into Power Source

e. To perform a routine operation in the AMPLIFIER mode, given a random gain of 100 V/V, set the controls as follows (see Figure 63):

- | | | |
|----|--------------------|----------------------------|
| 1) | Mode: | V |
| 2) | Offset polarity: | + |
| 3) | Range: | 0 - 1 KV (gain is 100 V/V) |
| 4) | Offset command: | 100 V |
| 5) | Compliance limit: | 50 |
| 6) | Compliance select: | I _t |
| 7) | DPM monitor: | voltage |
| 8) | Meter range: | 0 - 1 KV |

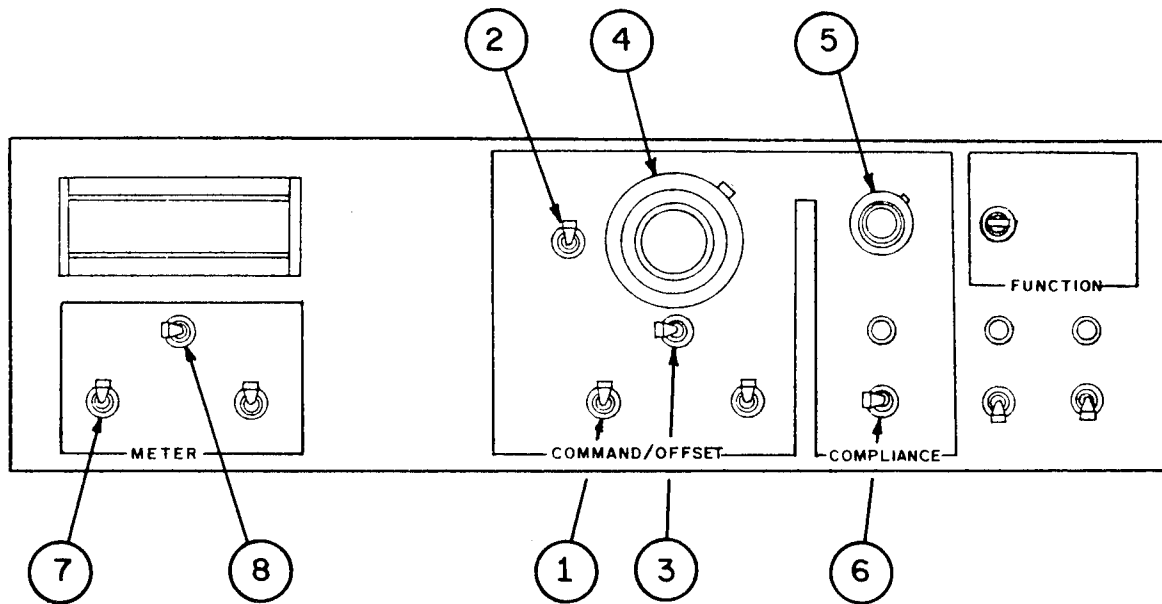

Figure 63. Example of Front Panel Settings

- f. On the front panel, flip the POWER switch to ON (see Figure 64).

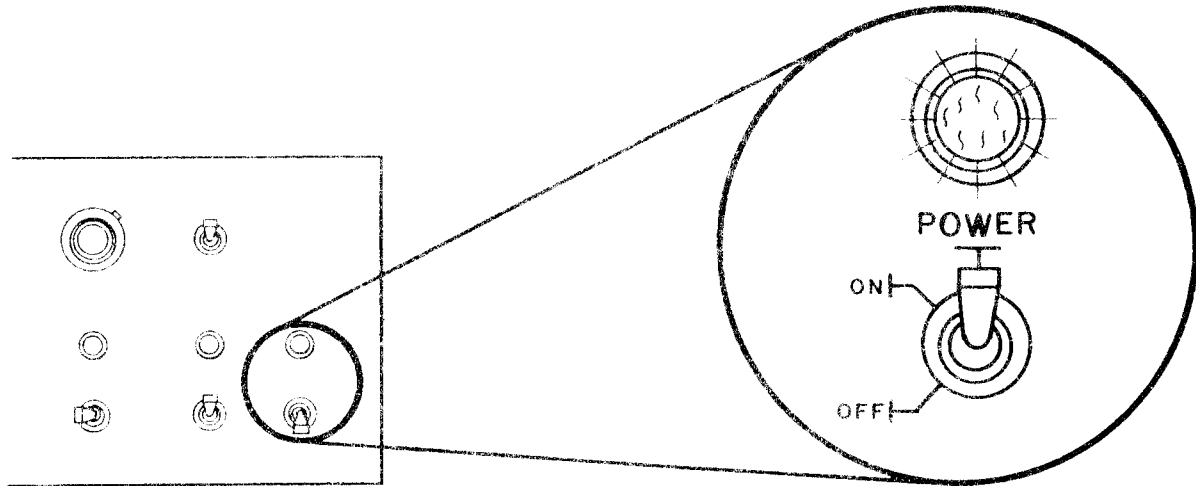

Figure 64. POWER Switch to ON

- g. Wait thirty seconds after the POWER switch has been set to ON, then flip the HV switch to ON (see Figure 65). The DPM displays the magnitude of voltage between HV OUT and ground.

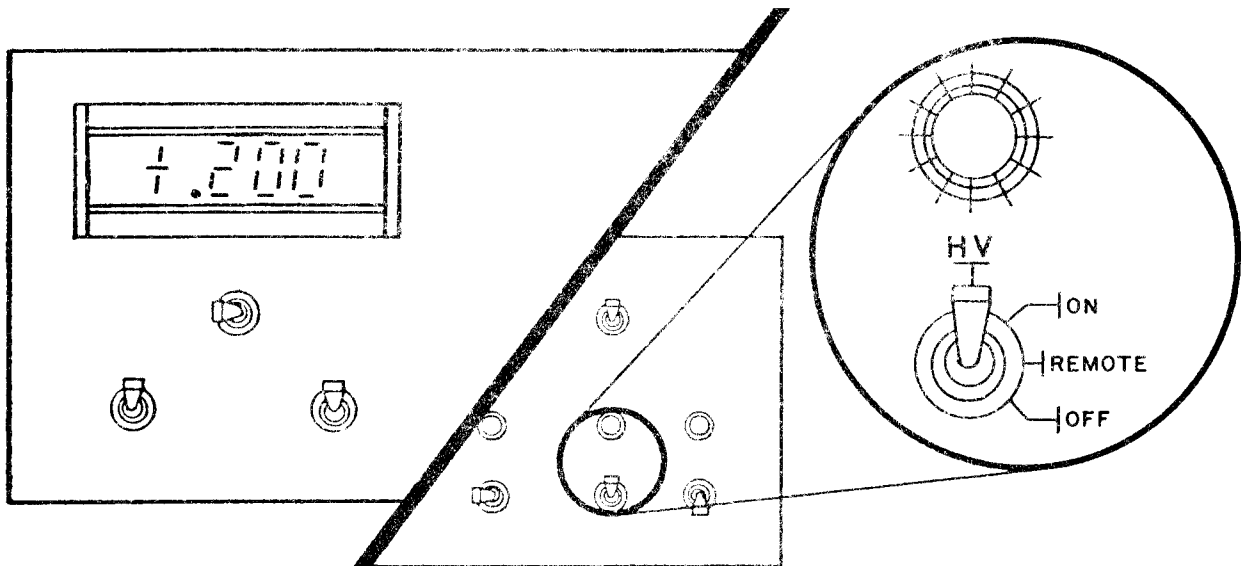

Figure 65. HV Switch to ON

NOTE

If the load condition is such that you are attempting to draw more current from the 610B than that set by the limit, then the output voltage is restricted.

EXAMPLE

With a set-up of the current limit set at the maximum 2000 μA and the supply voltage set at 500 V

For a resistive load of 300 kilohms:

1667 μA flows through the load

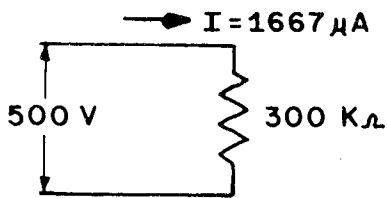

$$I = \frac{V}{R} = \frac{500 \text{ V}}{300 \text{ K}\Omega} = 1667 \mu\text{A}$$

With the same set-up

For a 200 kilohms load:

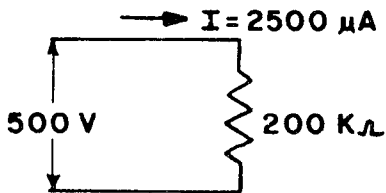

$$I = \frac{V}{R} = \frac{500 \text{ V}}{200 \text{ K}\Omega} = 2500 \mu\text{A}$$

The current is limited by the compliance function set to a maximum of 2000 μA .

Therefore the voltage at the HV OUT terminal is restricted to 400 V while 2000 μA is supplied.

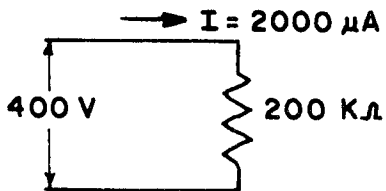

$$V = IR = (2000 \mu\text{A}) 200 \text{ K}\Omega = 400 \text{ V}$$

2.2.2.2 Transconductance Amplifier

As a transconductance amplifier, the gain is selectable and switch fixed.

2.2.2.2.1 I_r Output

The setup for operation in the AMPLIFIER mode with an I_r output and with a given set of random values is as follows:

- a. Ensure the POWER switch and the HV switch are set to OFF (see Figure 66).

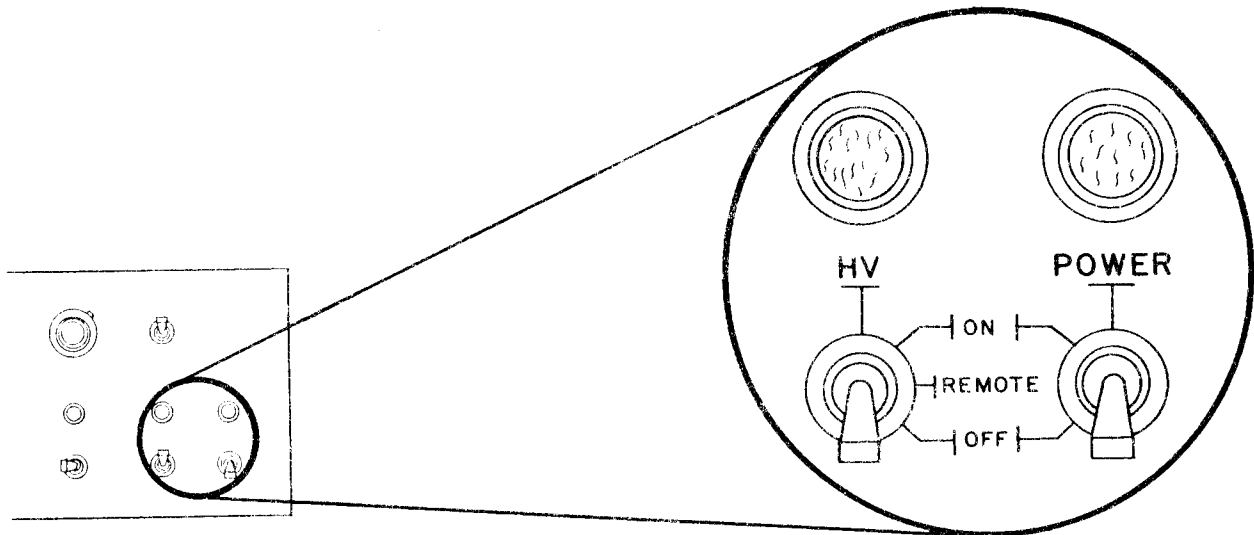

Figure 66. POWER and HV Switches to OFF

b. At the rear panel, make the connections (see Figure 67):

- 1) From HV OUT to the load
- 2) Return the load to the I_r terminal

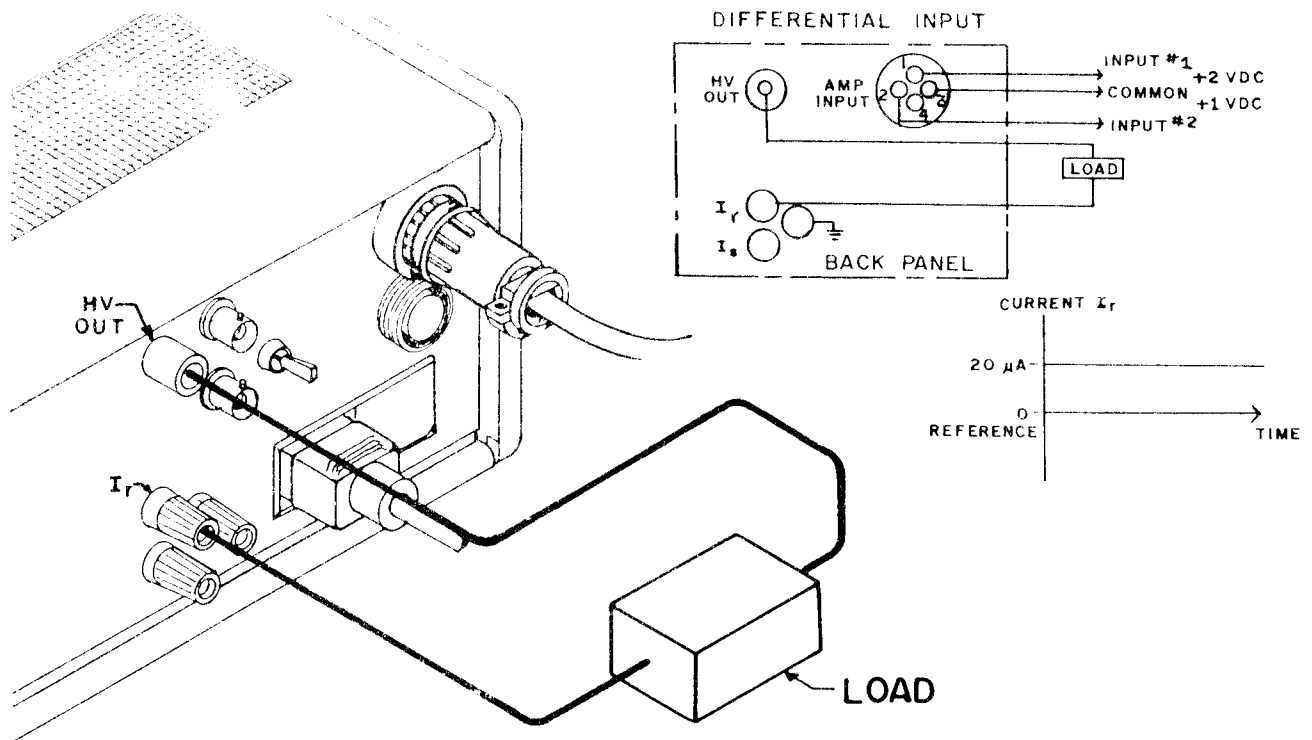

Figure 67. Example of Rear Panel Connections

- c. Plug the female connector on the AC power cord into the AC power receptacle on the rear panel of the 610B (see Figure 68).

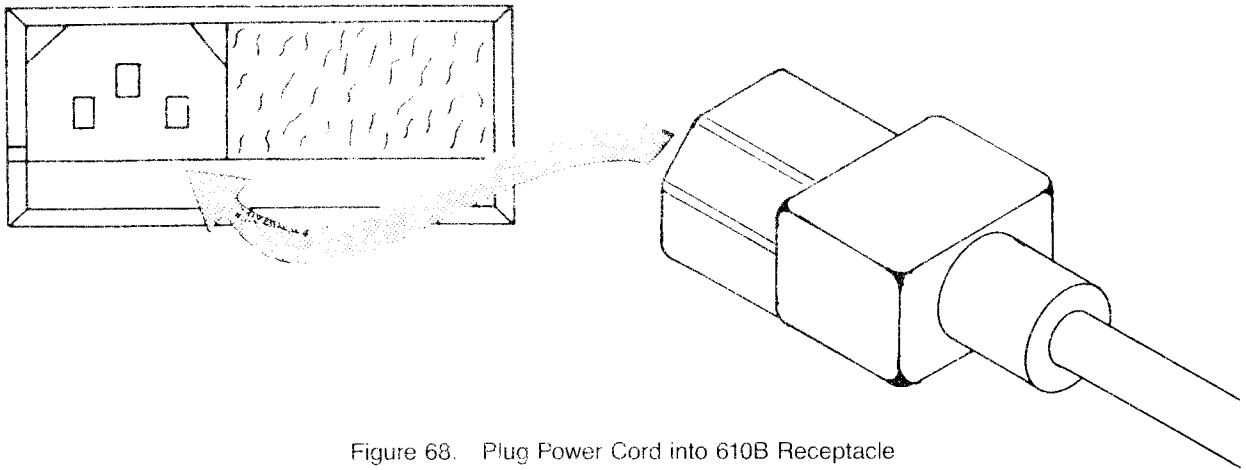

Figure 68. Plug Power Cord into 610B Receptacle

- d. Plug the power cord into a power source (see Figure 69).

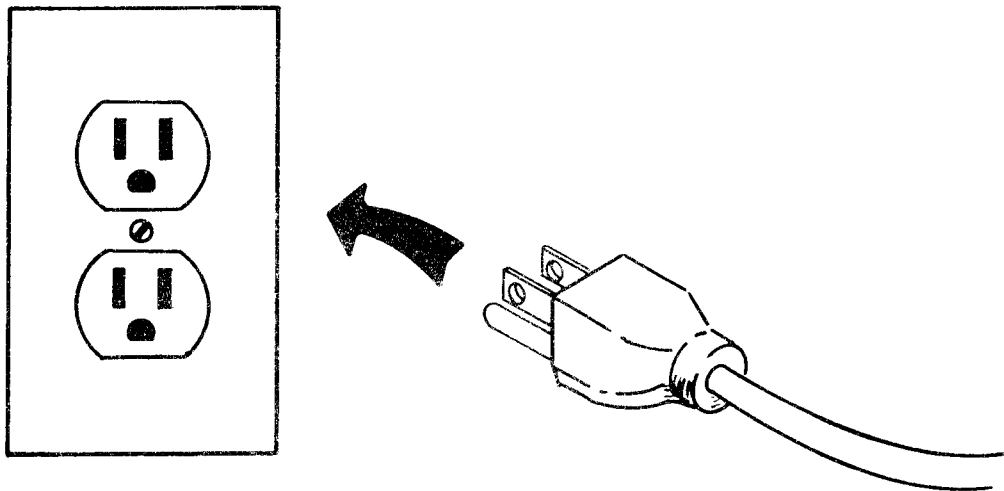

Figure 69. Plug Power Cord into Power Source

e. To perform a routine operation in the I_r AMPLIFIER mode, given a random gain of $20 \mu\text{A/V}$, set the controls (see Figure 70):

- | | |
|----------------------|--|
| 1a) Mode: | I_r |
| 1b) Offset polarity: | OFF |
| 2) Range: | 0 - 200 μA (gain is $20 \mu\text{A/KV}$) |
| 3) Offset magnitude: | Don't Care |
| 4) Compliance dial: | 50 (limiting voltage output at HV OUT connector to $\pm 5,000 \text{ V}$) |
| 6a) DPM monitor: | I_r |
| 6b) Meter range: | I_r |
| 7) Meter range: | 0 - 200 μA |

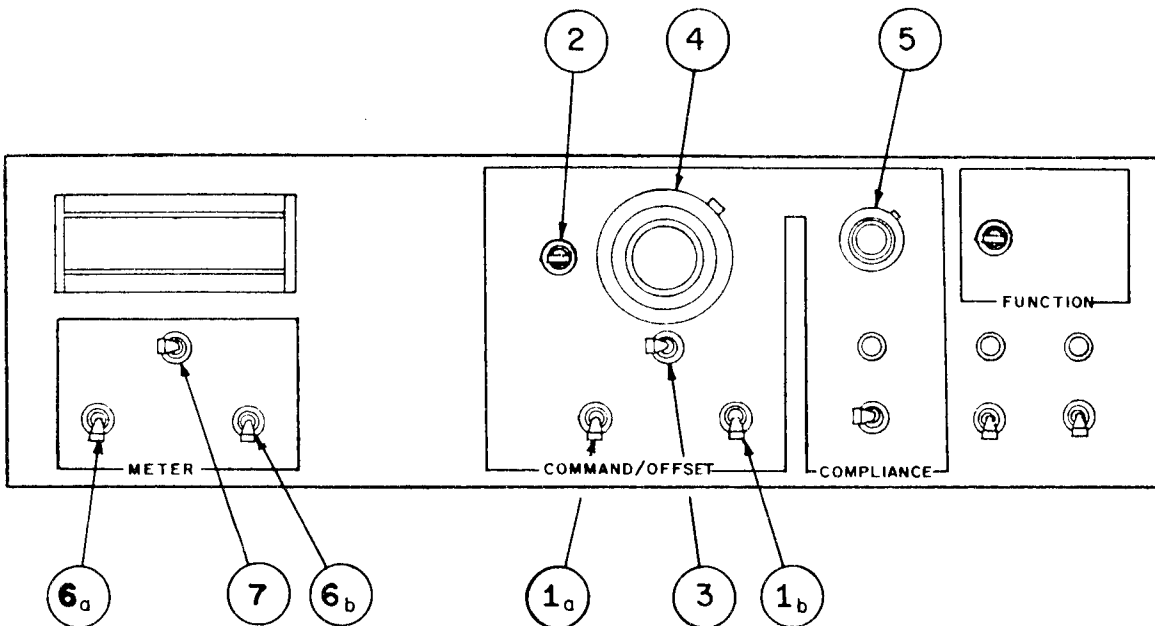

Figure 70. Example of Front Panel Settings

- f. On the front panel, flip the POWER switch to ON (see Figure 71).

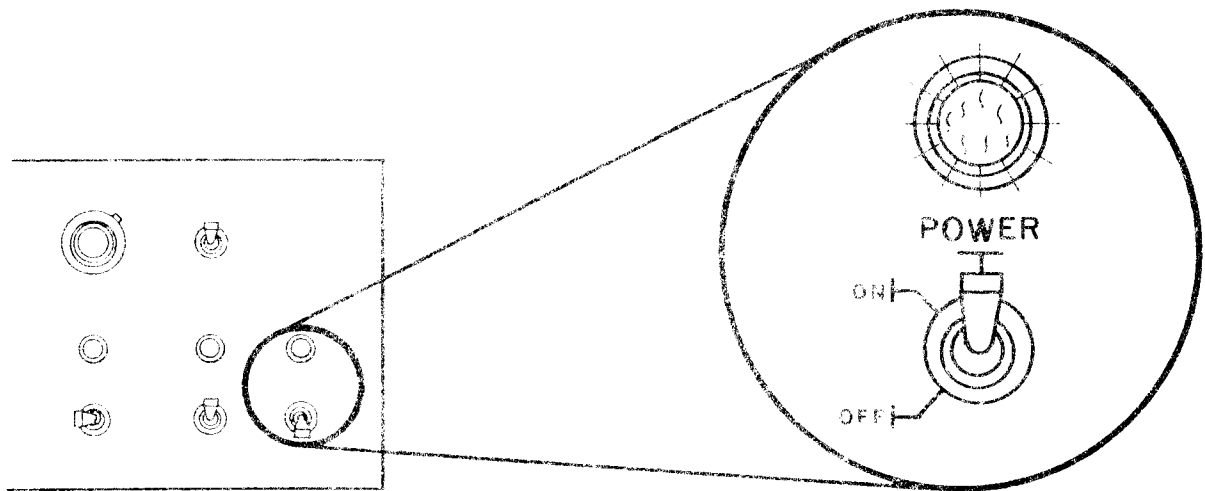

Figure 71. POWER Switch to ON

- g. Wait thirty seconds after the POWER switch has been set to ON, then flip the HV switch to ON (see Figure 72). The DPM displays the magnitude of current drawn by the load.

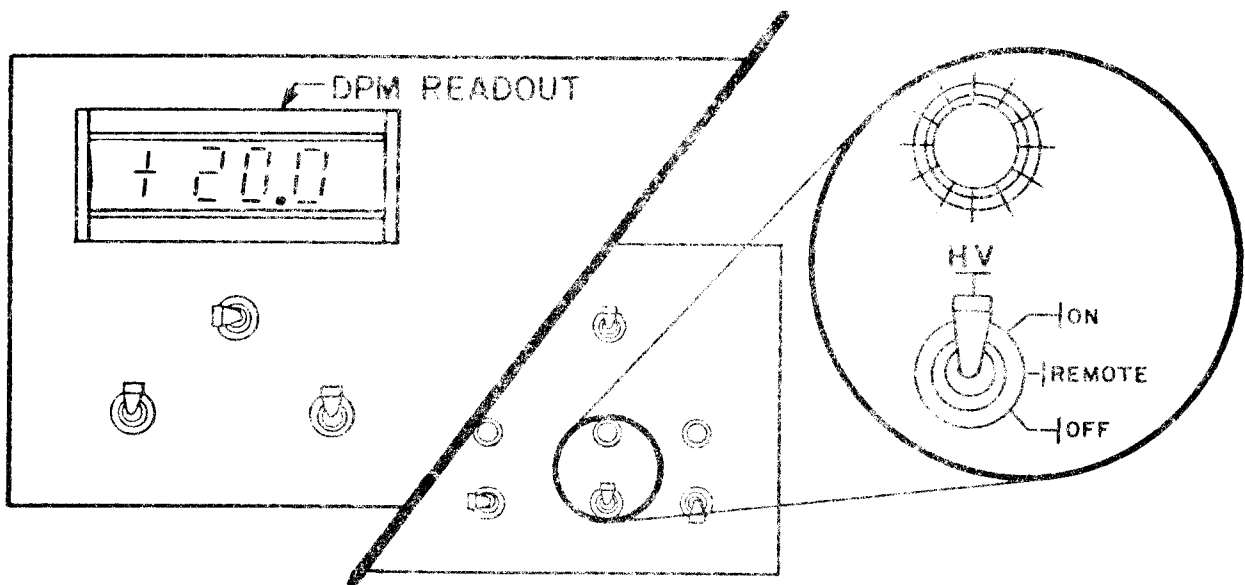

Figure 72. HV Switch to ON

NOTES

1) Current SUPPLY I_t and I_r

If the load condition is such that you are attempting to exceed the voltage limit set by the compliance function, then the output current is restricted.

EXAMPLE

For a resistive load of	22.5 M ohms
Voltage limit set at	8000 V
Supply current set at	400 μA

To supply 400 μA in a 22.5 M ohms load would require 9000 V

$$V = IR = (400 \mu\text{A}) (22.5 \text{ M ohms}) = 9000 \text{ V}$$

but the voltage available at the HV OUT receptacle is limited to 8000 V by the compliance function setting, therefore only 356 μA would be supplied to the load.

$$I = \frac{V}{R} = \frac{8000\text{V}}{22.5 \text{ M ohms}} = 356 \mu\text{A}$$

2) **When attempting to control current in an open path, no current will flow and the voltage across that path will be limited to the voltage value of the compliance function setting.**

2.2.2.2.2 I_t Output

The setup for operation in the I_t AMPLIFIER mode and with a given set of random values is as follows:

- a. Ensure the POWER switch and the HV switch are set to OFF (see Figure 73).

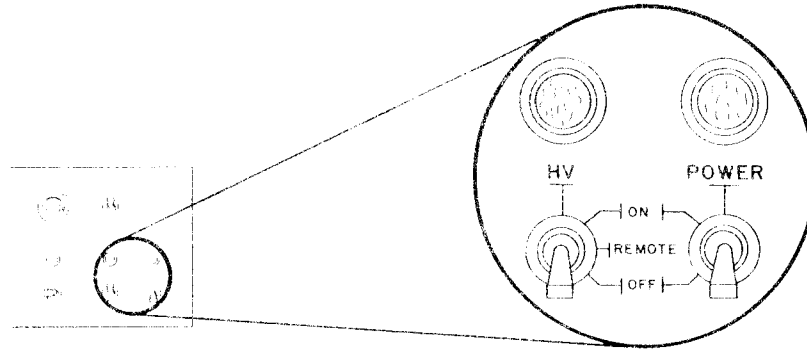

Figure 73. POWER and HV Switches to OFF

- b. At the rear panel, make the connections (see Figure 74):

- 1) From HV OUT to the load.
- 2) With shield wire to I_s
- 3) Return the load to I_r

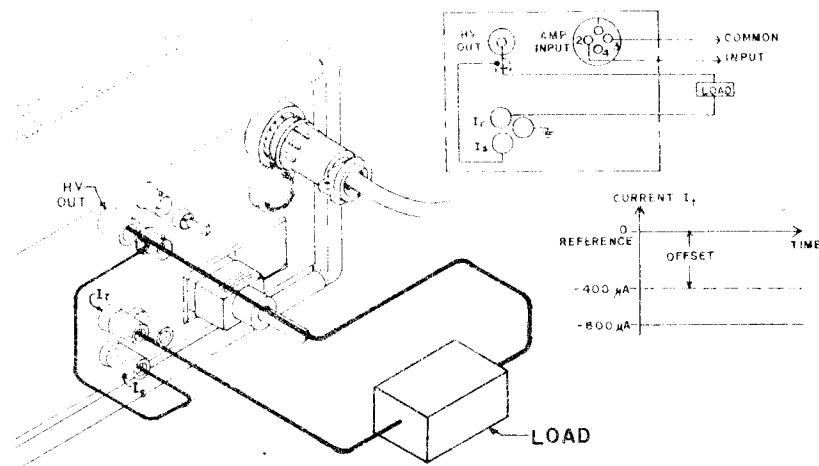

Figure 74. Example of Rear Panel Connections

- c. Plug the female connector on the AC power cord into the AC power receptacle on the rear panel of the 610B (see Figure 75).

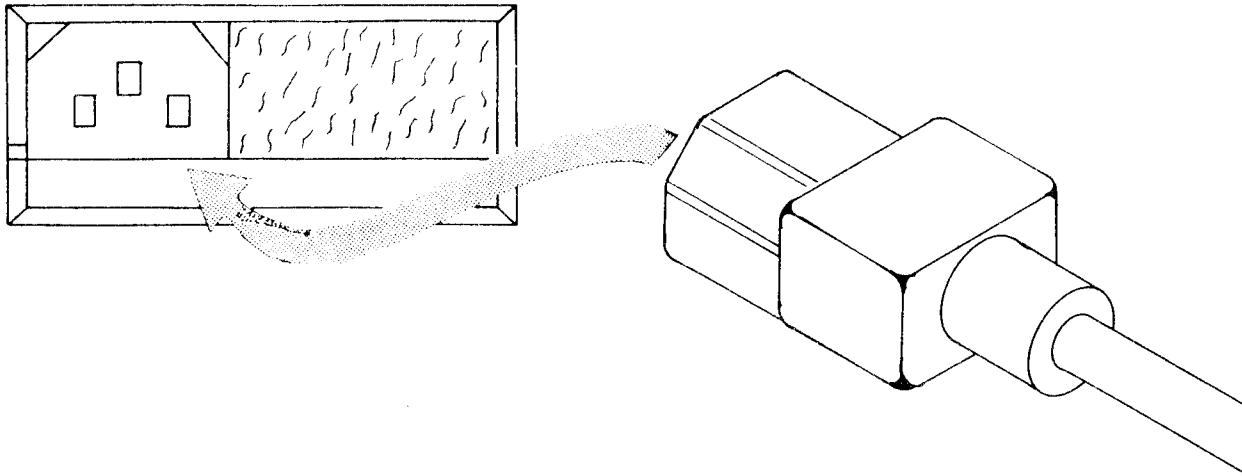

Figure 75. Plug Power Cord into 610B Receptacle

- d. Plug the power cord into a power source (see Figure 76).

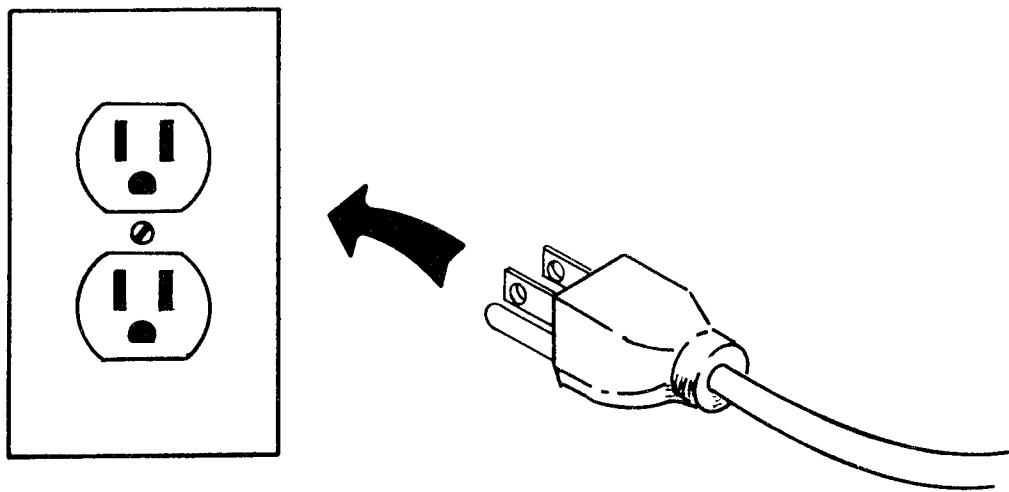

Figure 76. Plug Power Cord into Power Source

e. To perform a routine operation in the I_t AMPLIFIER mode, given a random gain of $200 \mu\text{A/V}$, set the controls (see Figure 77):

- | | |
|----------------------|---|
| 1a) Mode: | I |
| 1b) : | I_t |
| 2) Offset polarity: | - |
| 3) Range: | 0 - 2000 μA (gain is $200 \mu\text{A/V}$) |
| 4) Offset command: | 20 (400 μA) |
| 5) Compliance limit: | 50 (limiting voltage output at HV OUT connector to $\pm 5000 \text{ V}$) |
| 6a) DPM Monitor: | I |
| 6b) : | I_t |
| 7) Meter range: | 0 - 2000 μA |

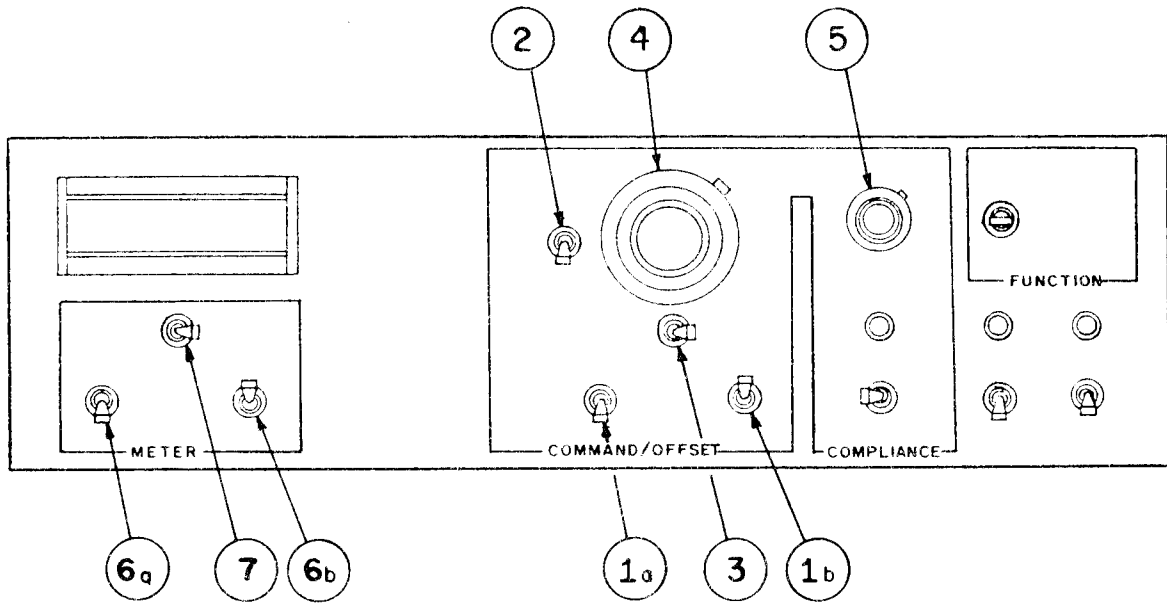

Figure 77. Example of Front Panel Settings

- f. On the front panel, flip the POWER switch to ON (see Figure 78).

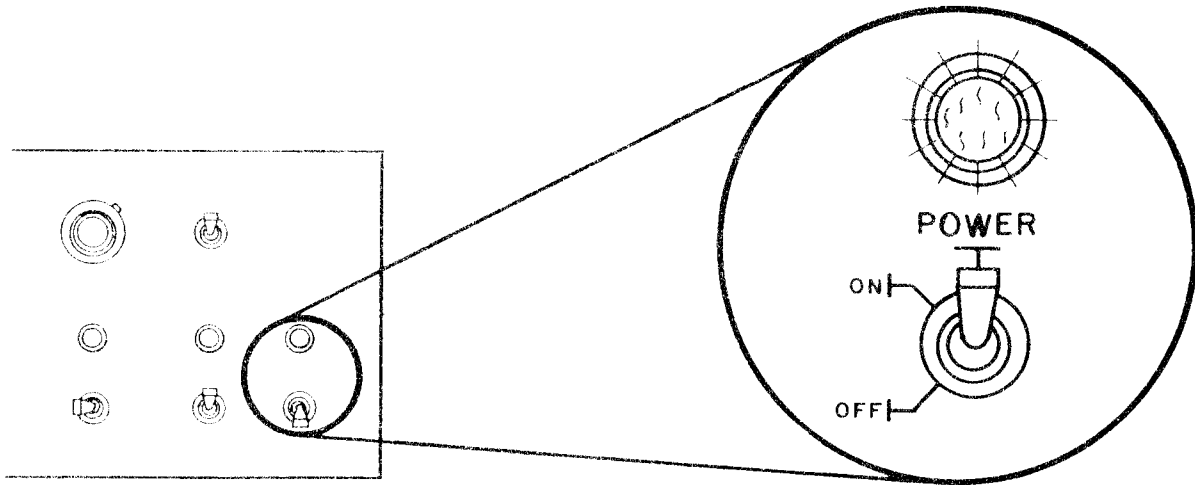

Figure 78. POWER Switch to ON

- g. Wait thirty seconds after the POWER switch has been set to ON, then flip the HV switch to ON (see Figure 79). The DPM displays the magnitude of the current drawn by the load.

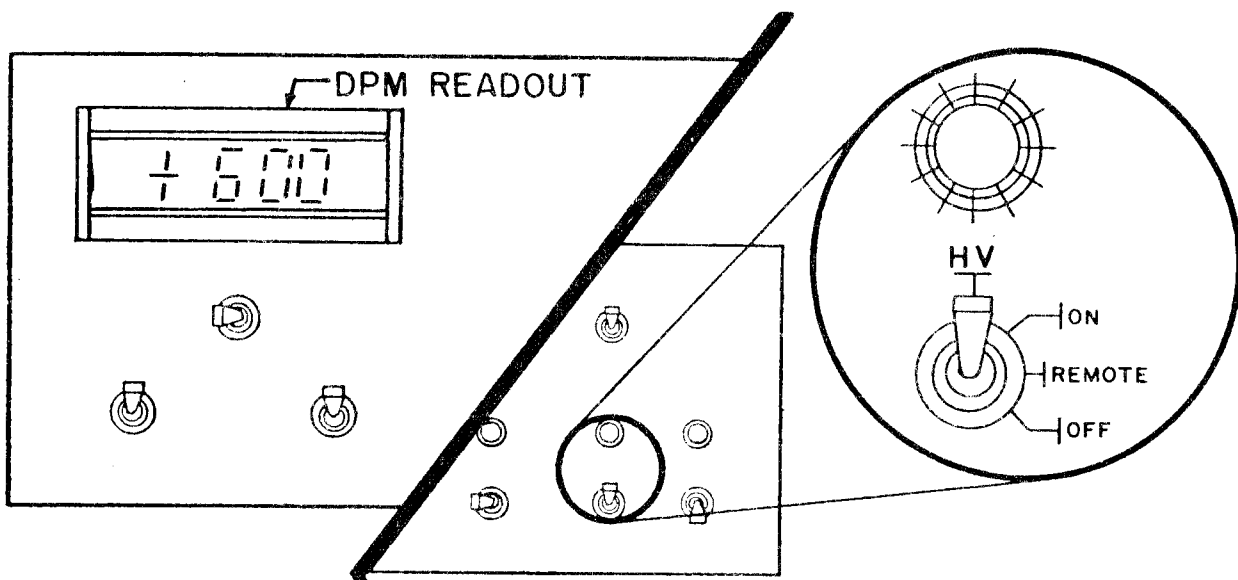

Figure 79. HV Switch to ON

NOTES

1) Current SUPPLY I_i and I_r

If the load condition is such that you are attempting to exceed the voltage limit set by the compliance function, then the output current is restricted.

EXAMPLE

For a resistive load of	22.5 M ohms
Voltage limit set at	8000 V
Supply current set at	400 μ A

To supply 400 μ A in a 22.5 M ohms load would require 9000 V

$$V = IR = (400 \mu\text{A}) (22.5 \text{ M ohms}) = 9000 \text{ V}$$

but the voltage available at the HV OUT receptacle is limited to 8000 V by the compliance function setting, therefore only 356 μ A would be supplied to the load.

$$I = \frac{V}{R} = \frac{8000\text{V}}{22.5 \text{ M ohms}} = 356 \mu\text{A}$$

2) When attempting to control current in an open path, no current will flow and the voltage across that path will be limited to the voltage value of the compliance function setting.

2.2.3 Controller Mode

In the CONTROLLER position, the 610B is a high-voltage operational amplifier. The amplifier's input and feedback parameters are determined by the components you elect to attach to the internal terminals.

The front panel controls function exactly as when in the AMPLIFIER position. The 610B as a controller element can function in a closed-loop control system (see Figure 80).

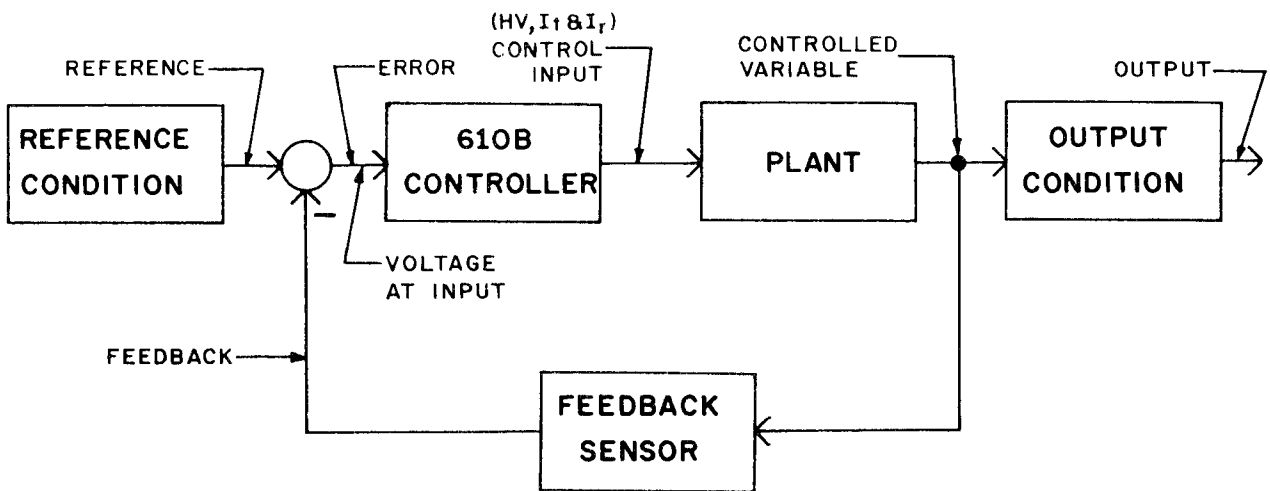

Figure 80. 610B as Controller in Closed-loop System

2.2.3.1 Controller Element Modified

The setup for operation as a modified integrator with a given set of random values is as follows:

- a. Ensure the POWER and HV switches are set to OFF (see Figure 81).

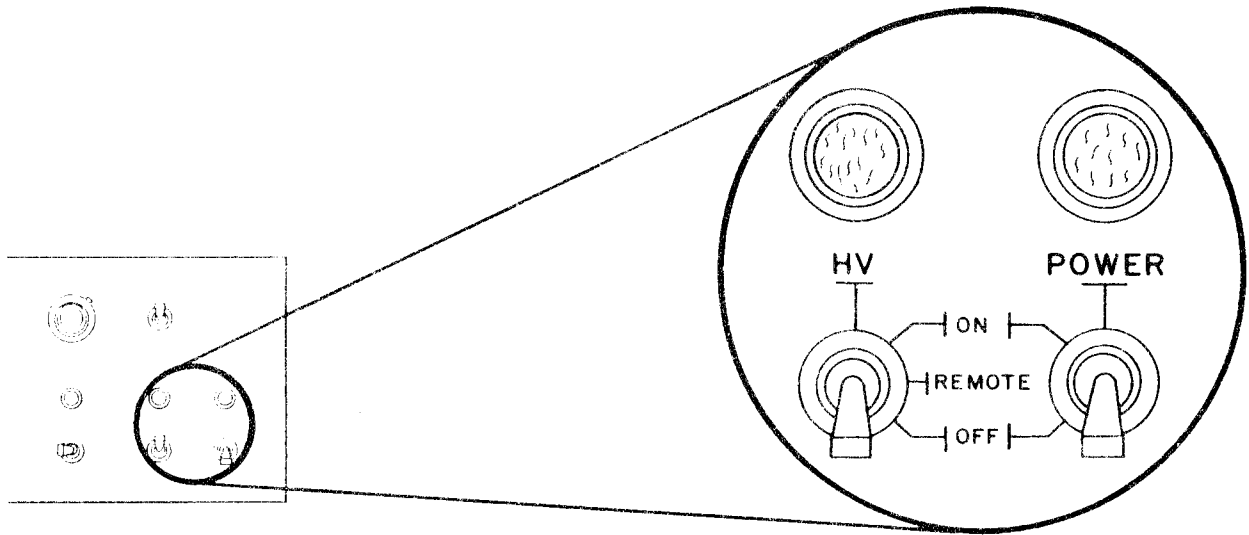

Figure 81. POWER and HV Switches OFF

- b. Make sure the power cord is disconnected from any power source if you have connected this cord (see Figure 82):

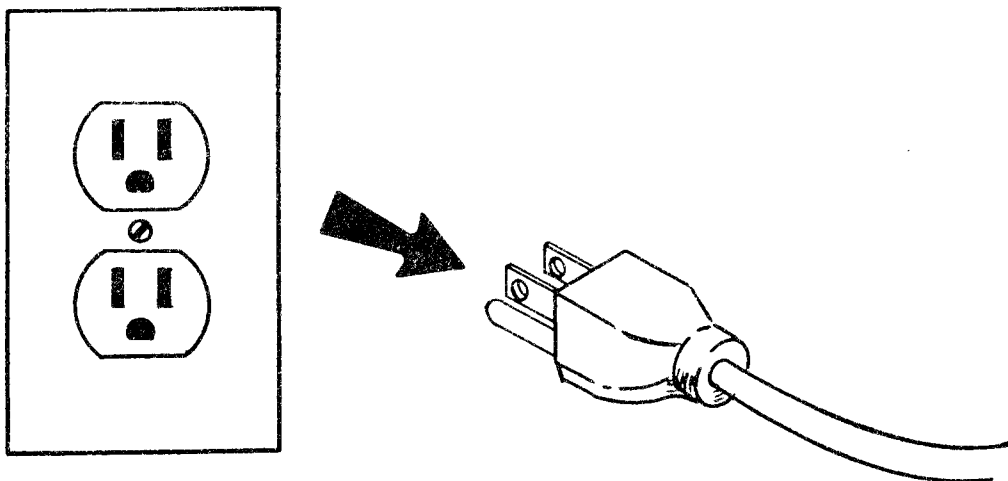

Figure 82. Disconnect Cord from Power Source

- c. Remove the four phillips-head screws in the top of the case. Remove the cover (see Figure 83).

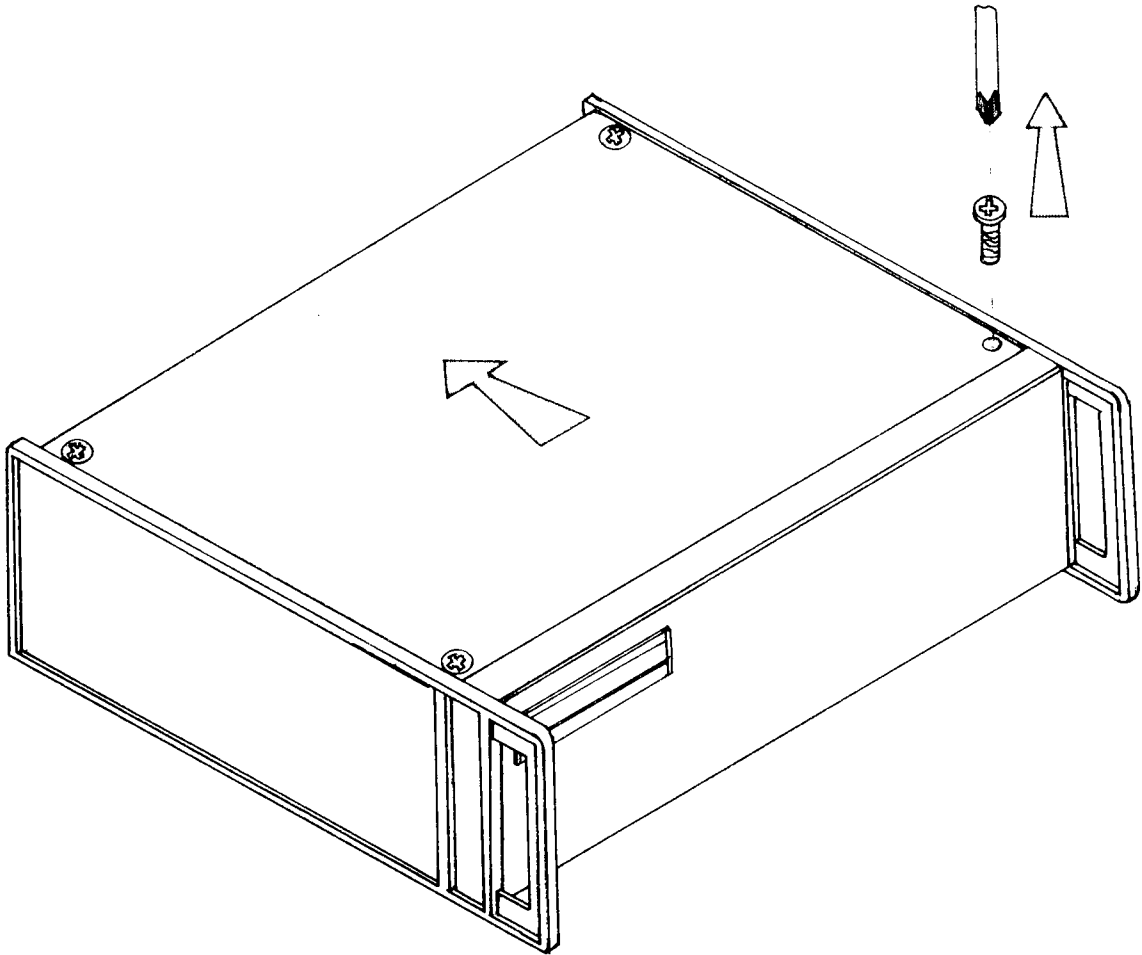

Figure 83. Remove 610B Cover

- d. Remove the resistor, R14, mounted on raised bases (see Figure 84). Replace resistor R14 with a capacitor of 0.1 uf at a minimum of 25 volt rating.

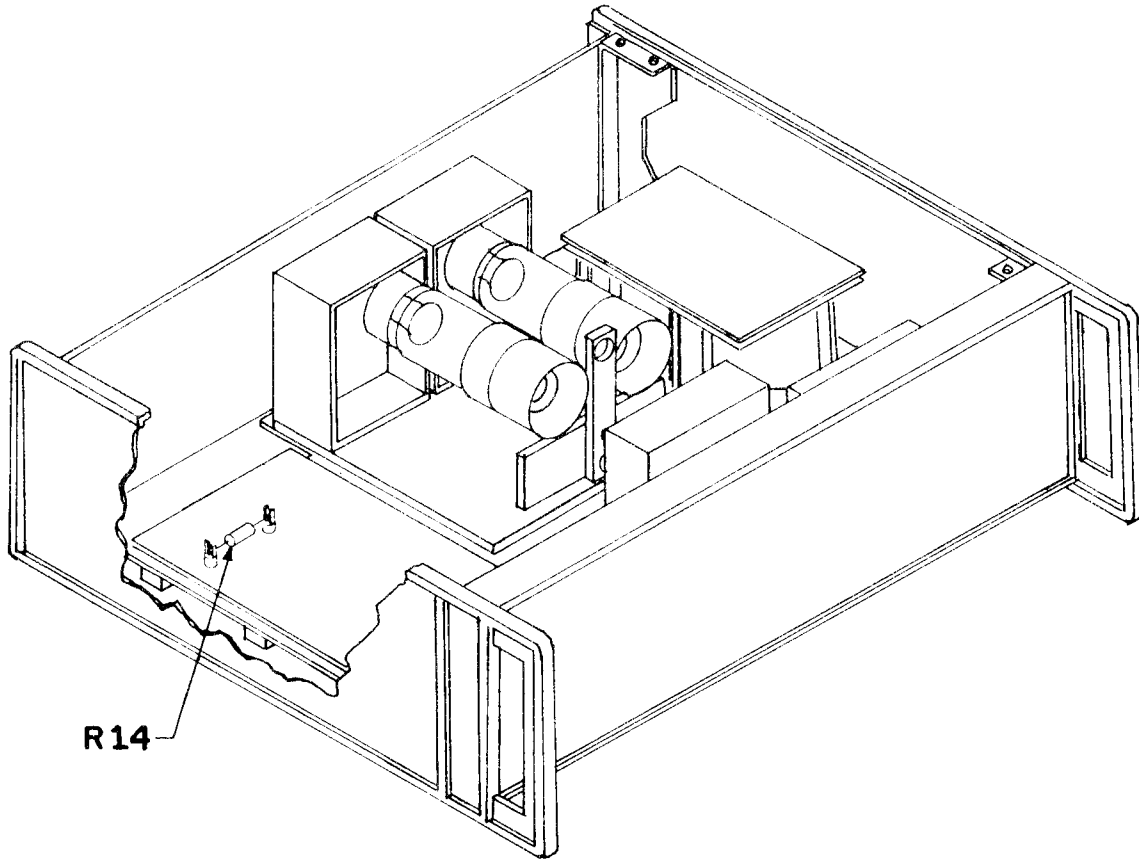

Figure 84. Remove R14 Resistor

e. Replace the 610B cover and the four screws (see Figure 85):

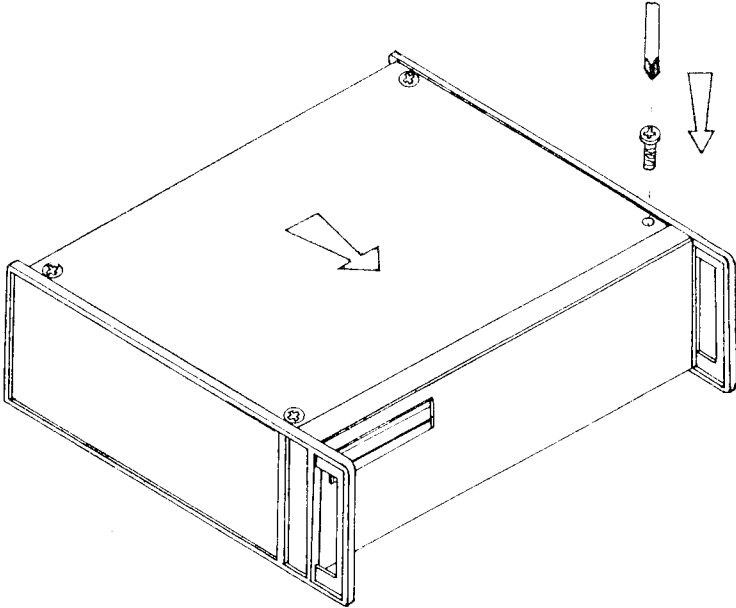

Figure 85. Replace Cover and Screws

f. At the rear panel, make the connections (see Figure 86):

- 1) From HV OUT to the load.
- 2) Return the load to ground (green receptacle).

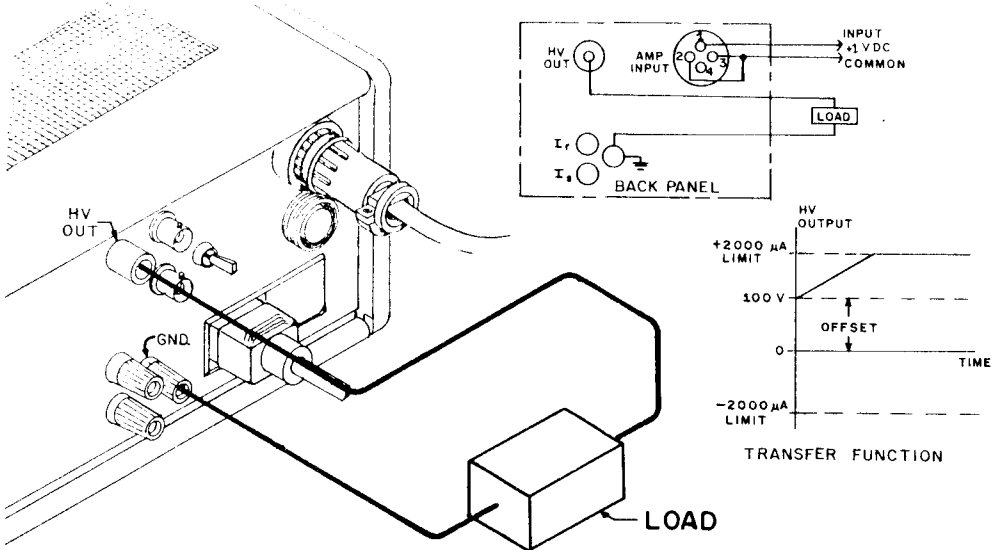

Figure 86. Example of Rear Panel Connections

- g. Plug the female connector on the AC power cord into the AC power receptacle on the rear panel of the 610B (see Figure 87).

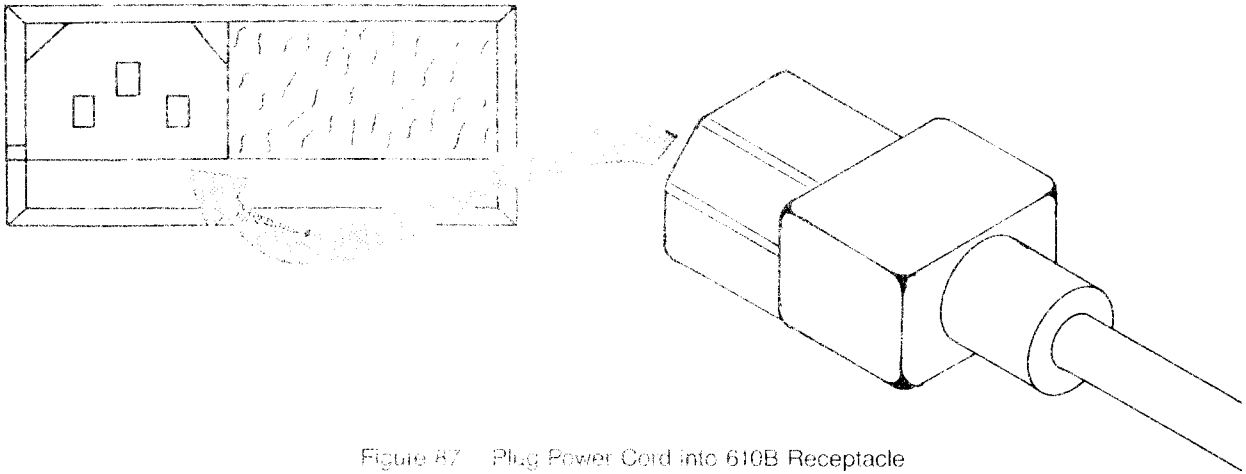

Figure 87. Plug Power Cord into 610B Receptacle

- h. Plug the power cord into a power source (see Figure 88).

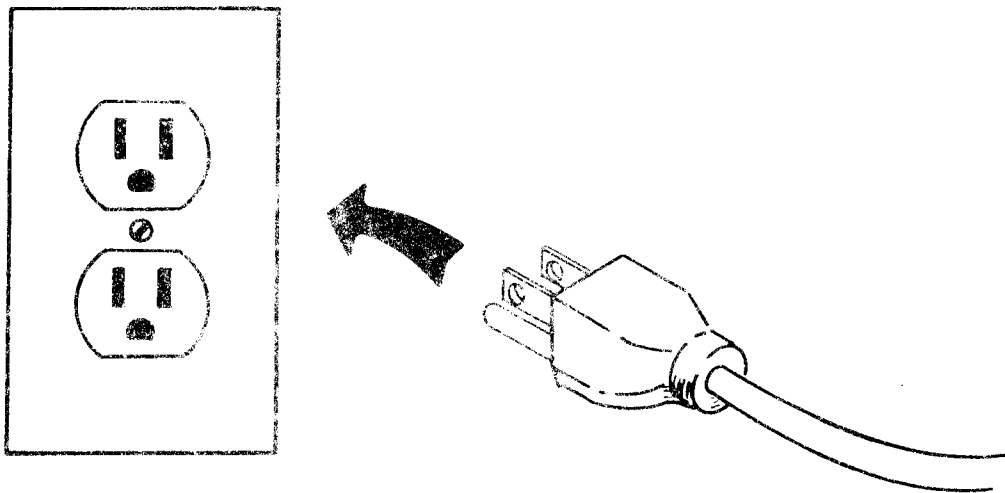

Figure 88. Plug Power Cord into Power Source

i. To perform a routine operation in the CONTROLLER mode, with the 610B acting as an integrator, given a random gain of 100V/V, set the controls as follows (see Figure 89):

- | | |
|-----------------------|--------------------------|
| 1) Mode: | V |
| 2) Offset polarity: | + |
| 3) Range: | 0 - 1 KV (gain = 100V/V) |
| 4) Offset command: | 100 V |
| 5) Compliance limit: | 100 |
| 6) Compliance select: | I_t |
| 7) DPM monitor: | voltage |
| 8) Meter range: | 0 - 1 KV |

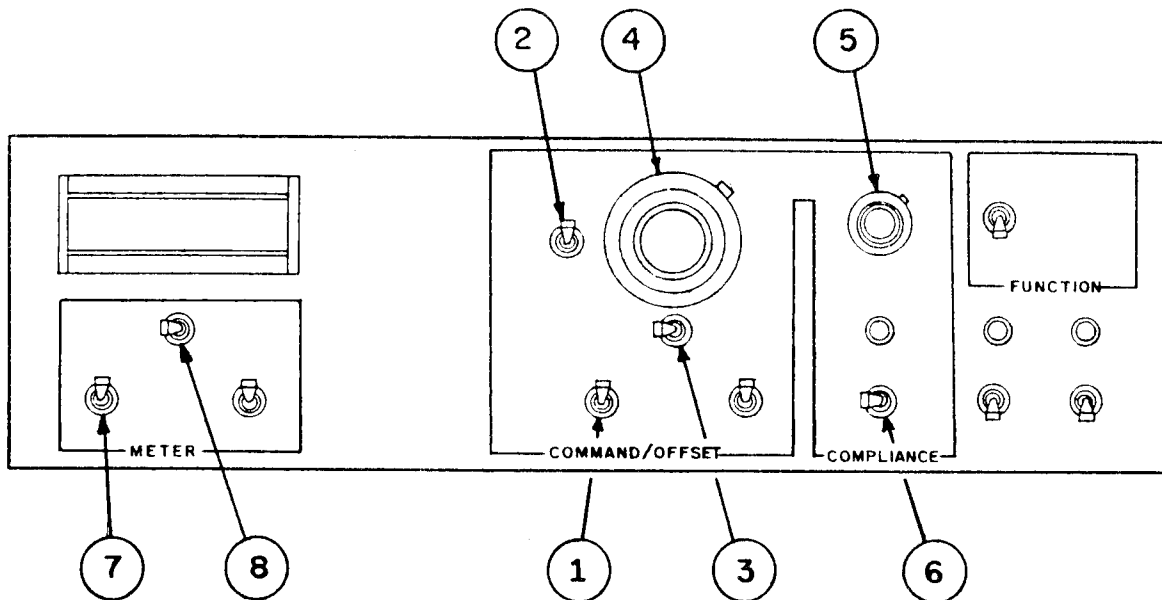

Figure 89. Example of Front Panel Settings

- j. On the front panel, flip the POWER switch to ON (see Figure 90).

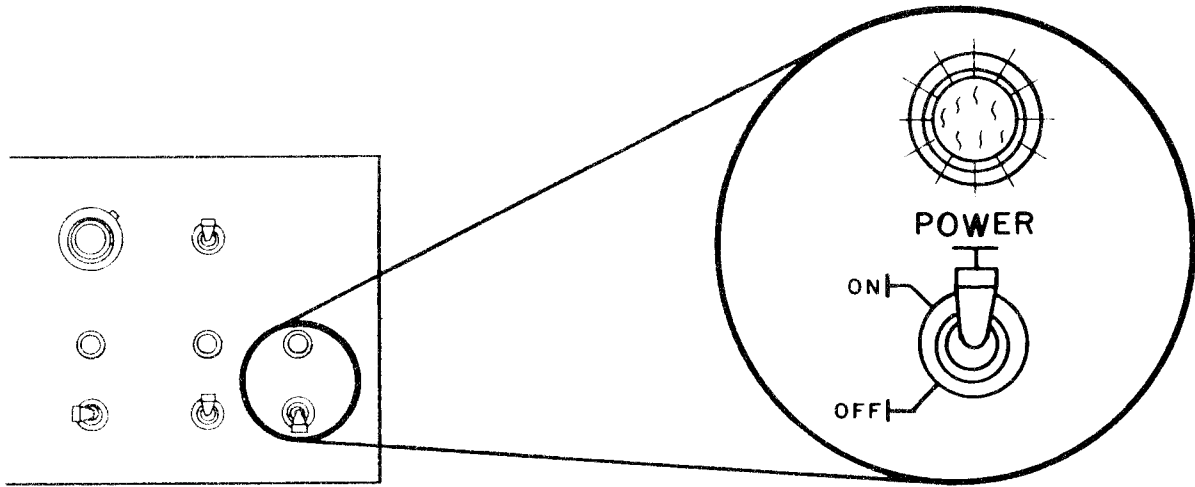

Figure 90. POWER Switch to ON

- k. Wait thirty seconds after the POWER switch has been set to ON, then flip the HV switch to ON (see Figure 91). The DPM displays the magnitude of voltage between HV OUT and ground.

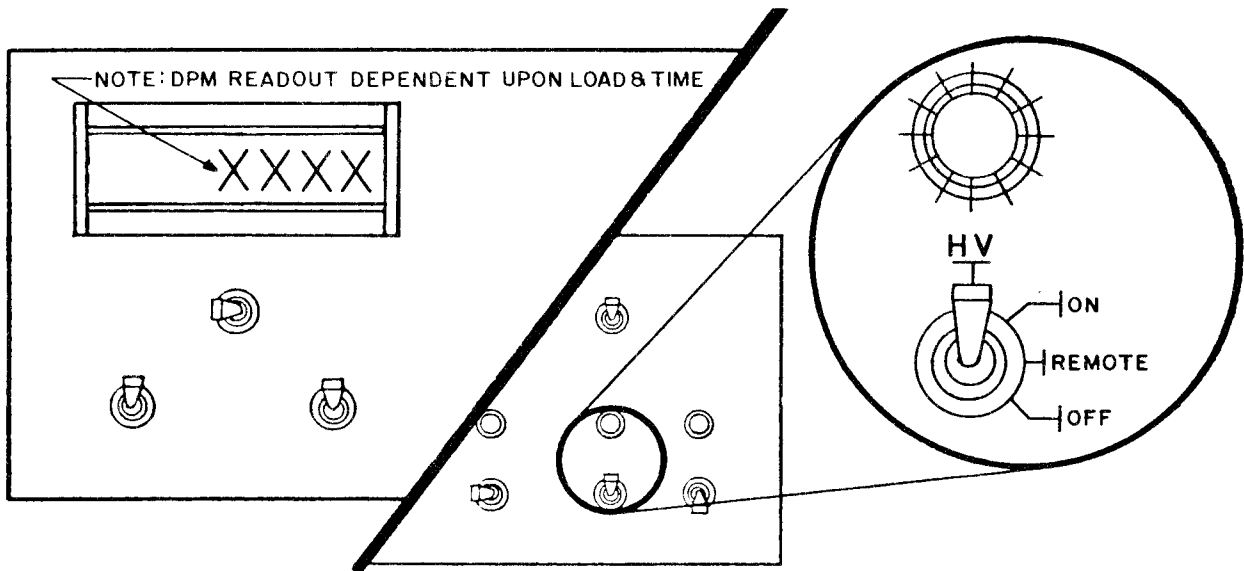

Figure 91. HV Switch to ON

NOTE

If the load condition is such that you are attempting to draw more current from the 610B than that set by the limit, then the output voltage is restricted.

EXAMPLE

With a set-up of the current limit set at the maximum 2000 μA and the supply voltage set at 500 V

For a resistive load of 300 kilohms:

1667 μA flows through the load

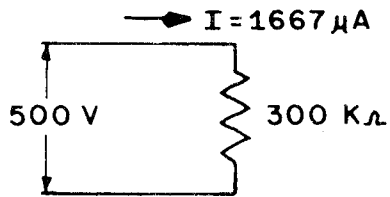

$$I = \frac{V}{R} = \frac{500 \text{ V}}{300 \text{ K}\Omega} = 1667 \mu\text{A}$$

With the same set-up

For a 200 kilohms load:

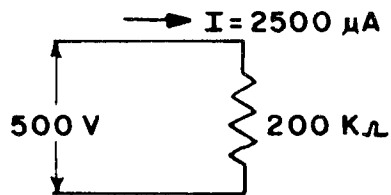

$$I = \frac{V}{R} = \frac{500 \text{ V}}{200 \text{ K}\Omega} = 2500 \mu\text{A}$$

The current is limited by the compliance function set to a maximum of 2000 μA .

Therefore the voltage at the HV OUT terminal is restricted to 400 V while 2000 μA is supplied.

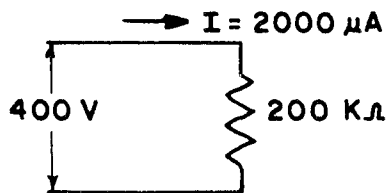

$$V = IR = (2000 \mu\text{A}) 200 \text{ K}\Omega = 400 \text{ V}$$

2.3 HOUSEKEEPING

The 610B is designed to keep frequent maintenance requirements to a minimum.

2.3.1 Clean Case

The simplest step in maintaining the appearance of your unit is to clean the case with a lint-free cloth moistened with a solution of one-half denatured alcohol and one-half water (see Figure 92). Ensure that no cleaning solution drips into the vent slots.

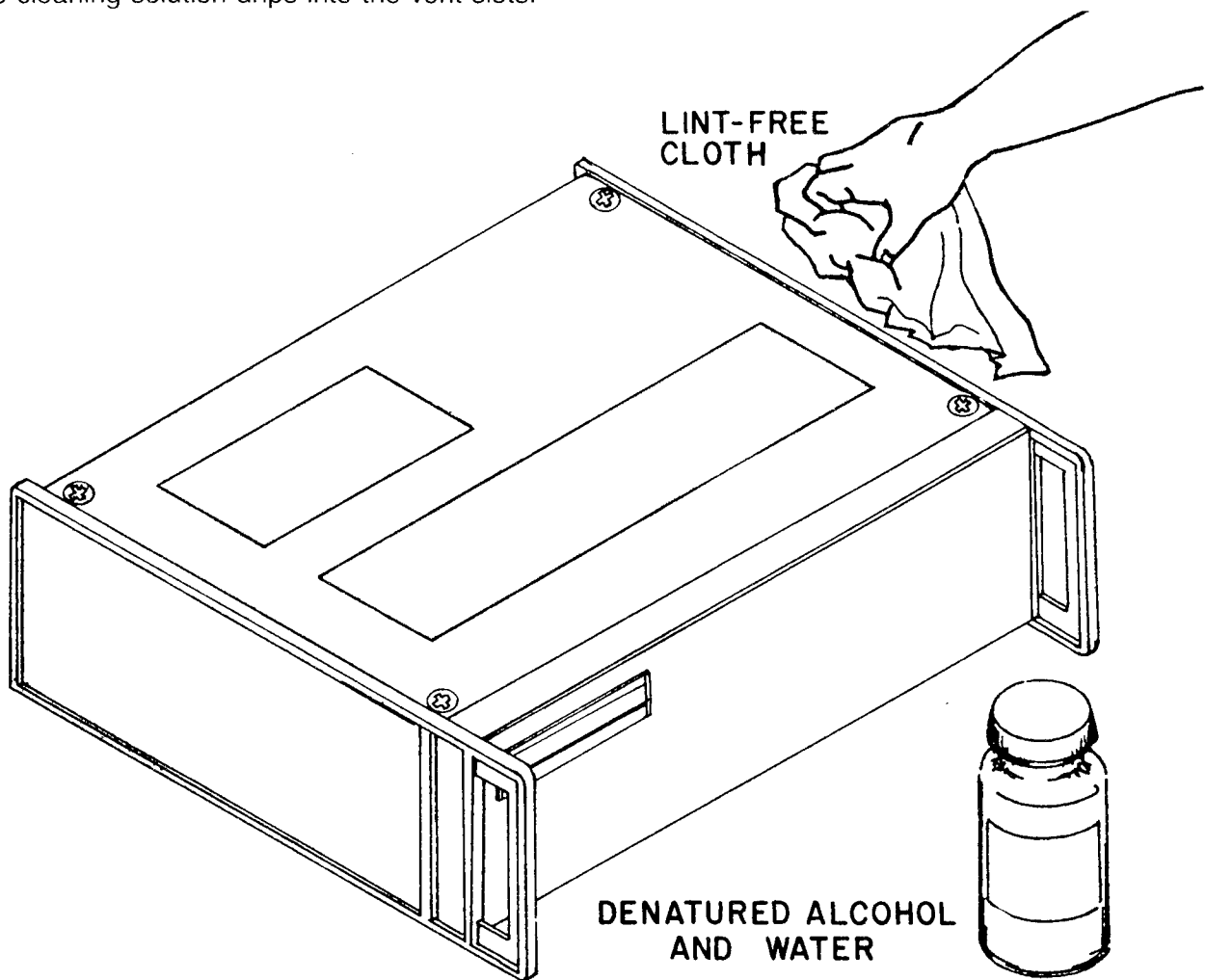

Figure 92. Cleaning the Case

2.3.2 Parts Replacement

After approximately 5,000 hours of use, estimated every two years, the output regulators (tubes) should be replaced (see Figure 93).

To replace these parts:

- 1) Remove the screws as indicated by "A" in Figure 93.
- 2) Remove the sleeves from over the tubes as indicated by "B" in Figure 93.
- 3) Remove the tubes as indicated by "C" in Figure 93.
- 4) Install the new tubes.
- 5) Reinstall the sleeves (B) over the new tubes.
- 6) Reinstall the screws (C).

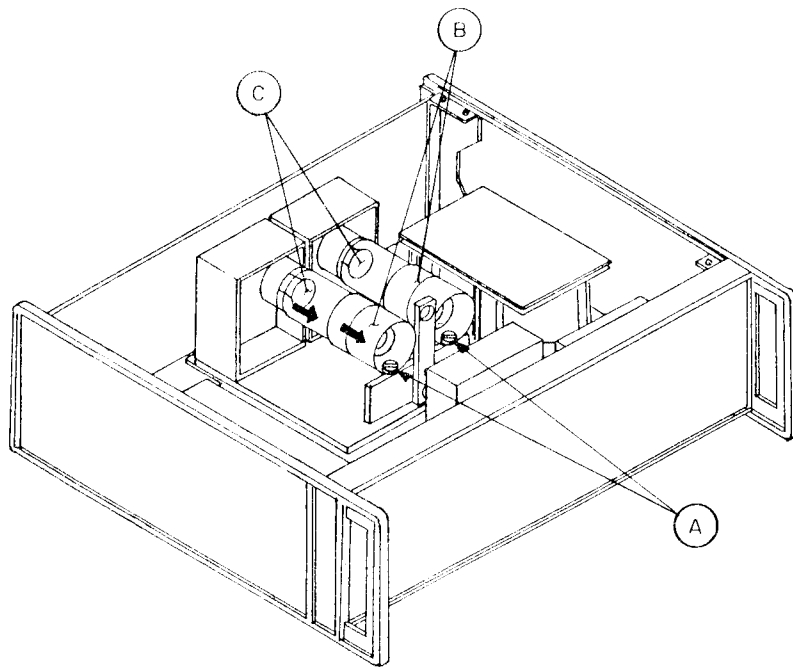

Figure 93. Parts Replacement

SECTION III THEORY OF OPERATION

3 DESCRIPTION

The 610B Cor-a-trol is a bipolar, four-quadrant, high-speed, high-voltage, operational amplifier system. The 610B is self-contained (see Figure 94). It is a versatile, analog instrument. You have precision control of voltage and current at its output terminals.

To operate the 610B you need only a standard AC power source. The internal voltage supplies are the high-frequency, low stored energy type that reduces the potential shock hazard to users. The use of overvoltage protection on the inputs and ultrafast output current limit virtually eliminates the possibility of damage from input overvoltage and output short circuit conditions.

WARNING

This equipment is capable of generating voltages as high as 12,000 V. This voltage is generated using high-frequency supplies to limit the available energy. Use caution in handling the output of the 610B to avoid injury.

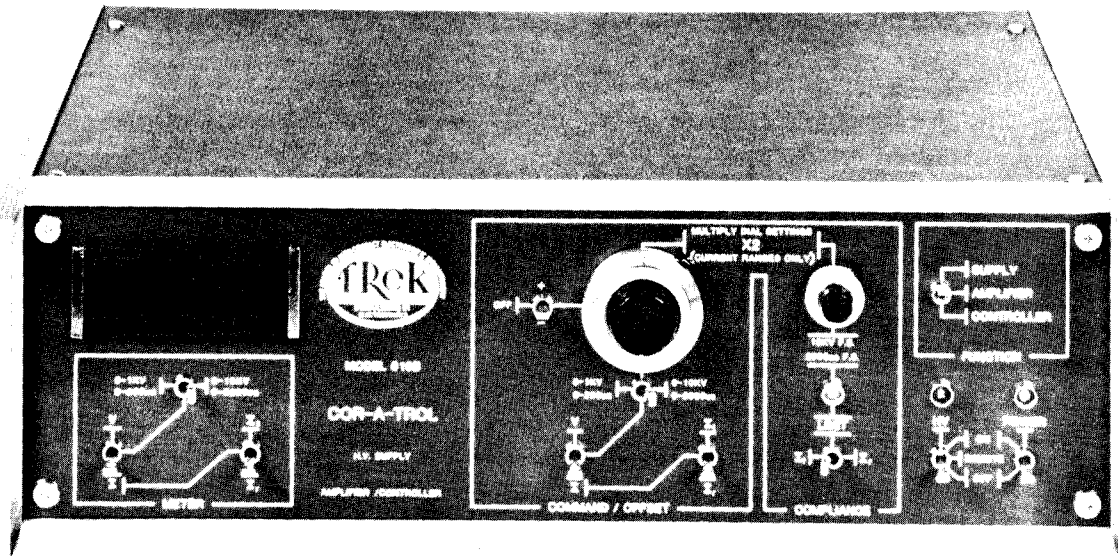

Figure 94. The 610B Cor-a-trol

3.1 THEORY OF OPERATION

The 610B Cor-a-trol can operate in three different modes: SUPPLY, AMPLIFIER and CONTROLLER. In all modes, transconductance operation can be either from total output current, measured at the HV OUT terminal, I_t , or from the current return terminal, I_r . If regulation of a single current path is desired in the presence of multiple loads on the output of the unit, then the ability to regulate the I_r is useful. The I_s terminal permits termination of an unmonitored current path in the I_t mode.

3.1.1 Supply

When the 610B Cor-a-trol is used as a supply, the input to the amplifier is connected to an adjustable, precision voltage reference that allows you to control and maintain the amplifier's output voltage or current. The choice of output voltage or current is switch selectable.

3.1.2 Amplifier

In the amplifier mode, the output (current or voltage) is selectable. You can select a fixed voltage gain or a fixed transconductance gain. The input configuration may be either single-ended, normal or inverted, + or -, or differential with good common mode rejection.

3.1.3 Controller

In the controller mode the input configuration is maintained just as in the amplifier mode but the amplifier's input and feedback parameters are uncommitted. The adjustable reference is connected to permit setting of the output (voltage or current) at a pedestal or reference level.

SECTION IV SPECIFICATIONS

4 SPECIFICATIONS

The 610B operates in three modes: Supply, Amplifier, and Controller.

4.1 GENERAL INFORMATION

Digital Display

3½ digit DC voltmeter
0.1% ±1 digit accuracy selectable to monitor output voltage or output current.

Controls

Power and high voltage ON/OFF on front panel.

HV remotely by EXT. CONTROL connector on back panel.

Outputs

Voltage: 0 to ± 10 KV, 0 to ± 1 KV
Current: 0 to ± 2000 μ A, 0 to ± 200 μ A

Monitor Output

Voltage and current monitor outputs available at the BNC connectors on the back panel.

Voltage: 10 V/10 KV
Current: 2000 μ A in = 10 V out

Line Supply

100/110/220 VAC 50-60 Hz

Slew Rate

20 V/ μ second

Dimensions

5 $\frac{1}{4}$ " H x 17" W x 15" D

Weight

25 lbs.

Mounting

Optional rack mounting hardware available.

4.2 VOLTAGE SUPPLY

Resolution

Output voltage adjustable by ten-turn, 1,000 division potentiometer;

Each division equals 10 V for 10 KV range.

Each division equals 1 V or 1 KV range.

Ranges

0 to $\pm 10,000$ V at ± 2000 μA maximum

0 to $\pm 1,000$ V at ± 2000 μA maximum

Regulation

line: $>.01$ percent for a line change from 105V to 125 V.

load: $>.01$ percent for a load change from 1 μA to 1,000 μA .

Stability

temperature: better than .01 percent/ $^{\circ}\text{C}$.

time: better than .01 percent/day.

Noise and Ripple

<0.7 V RMS $+ .001$ percent per mA of load current.

Settling Time

<1.0 microsecond to 0.1 percent for a step change of 10 KV.

Slew Rate

Better than 20 V/ μsec .

4.3 CURRENT SUPPLY

Resolution

Output current adjustable by ten-turn, 1,000 division potentiometer:

each division = $0.2 \mu\text{A}$ on $200 \mu\text{A}$ range
= $2.0 \mu\text{A}$ on $2,000 \mu\text{A}$ range

Ranges

0 to $\pm 2,000 \mu\text{A}$ at $\pm 10 \text{KV}$ (maximum) covered in two ranges:

$0 \mu\text{A}$ to $\pm 200 \mu\text{A}$
 $0 \mu\text{A}$ to $\pm 2,000 \mu\text{A}$

Regulation

line: $>.01$ percent for a line change from 105V to 125V .
load: $>.01$ percent for a load change from 10V to $10,000 \text{V}$.

Stability

temperature: better than $.01$ percent/ $^{\circ}\text{C}$.
time: better than $.01$ percent/day.

Noise and Ripple

I_r mode: $<17 \mu\text{A RMS} + .001$ percent for each 10KV change.

I_t mode: $<17 \mu\text{A RMS} + .001$ percent for each 10KV change.

Settling Time

I_r mode: $<1.0 \text{ms}$ to 0.1 percent for a $1,000 \mu\text{A}$ step change.

I_t mode: $<20 \text{ms}$ to 0.1 percent for a $1,000 \mu\text{A}$ step change.

4.4 AMPLIFIER AND CONTROLLER

Input Offset

voltage: ± 2.0 V at the output.
current: ± 50 pA maximum.

Input Bias Current

± 100 pA maximum.

Input Voltage Range

± 14 V maximum.

Voltage Gain

output to input: 1,000 V/V or 100 V/V (switch selectable)

Common Mode Rejection Ratio

60 dB at 60 Hz

Offset Voltage Temperature Coefficient

ambient temperature: 0°C to 50°C = 6 mV per degree C

Offset Current Temperature Coefficient

ambient temperature: 0°C to 50°C = .02 mA per degree C

Output Swing

voltage: ± 12 KV maximum.
current: $\pm 2,000$ μA maximum.

Noise and Ripple

<0.7 V RMS +.001 percent mA of load current.

Output Capacitance

100 pf

Bandwidth

I_r mode: 12 MHz gain bandwidth product (μA per V times frequency).

I_t mode: 600 KHz gain bandwidth product (μA per V times frequency).

Slew Rate

0 KV to ± 10 KV = 20V per μsec .

4.5 COMPLIANCE CONTROL

Ranges

100 V to 10,000 V adjustable to within 20 V while in the current modes.

2 μA to 2,000 μA adjustable to within 5 μA while in the voltage mode.

An indicator illuminates at the compliance limit.